









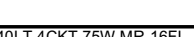

**KEY**

-  Source Four 19° 750W
-  Source Four 26° 750W
-  Source Four 36° 750W
-  Source Four PAR WFL 750W
-  10" Fresnel 2000W
-  40LT 4CKT 75W MR-16FL
-  40LT 4CKT MR-16FL MINI-STRIP 750W

**TYPICAL UNIT**

-  IRIS
-  UNIT NUMBER
-  CHANNEL
-  SIDEARM
-  LAMP DIRECTION

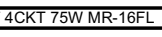
**NOTES**

- Breaks in catwalk pipes are walkways.
- Lights in catwalks are arranged to best overcome the presence of various physical obstructions.
- S=Strip, E=Electric, SP=Spare Pipe.
- Mini-Strip Gel Equivalencies: Red=G250, Blue=R83 (gel), Green=R90;
- 4S gel inc. R104 (striations US-DS) + R119
- Iris units on 2nd Catwalk are focused for classes & may not be refocused without permission of TD.
- Pit Low Wash units in dimmers 1, 6, 13, 20, 22, & 46 are focused for classes & may not be refocused at certain times of year. Please check with TD.
- Rep Patch is One-to-One (except for house lights).
- Orchestra Shell stores upstage behind cyc when soft goods are in use.

**Repertory Light Plot**

**Tsai Performance Center  
at Boston University**  
685 Commonwealth Ave.  
Boston, MA 02215

Designed by JoLaine Hall

Scale: 1/4"=1'-0"  
July 26, 2021

