

# Lab 5: Visible Light Data Communication

## SUMMER CHALLENGE COURSE SMART LIGHTING

Fulya Kaplan  
fkaplan3@bu.edu

Ayse Coskun  
acoskun@bu.edu

## Optical Modulation:

- Intensity-Modulation (IM) and Direct-Detection (DD)

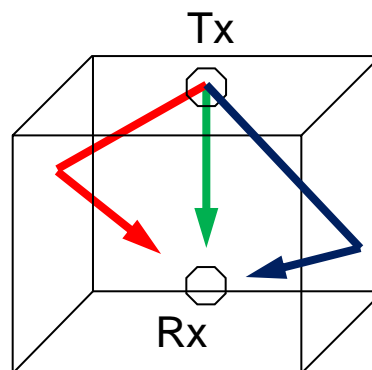
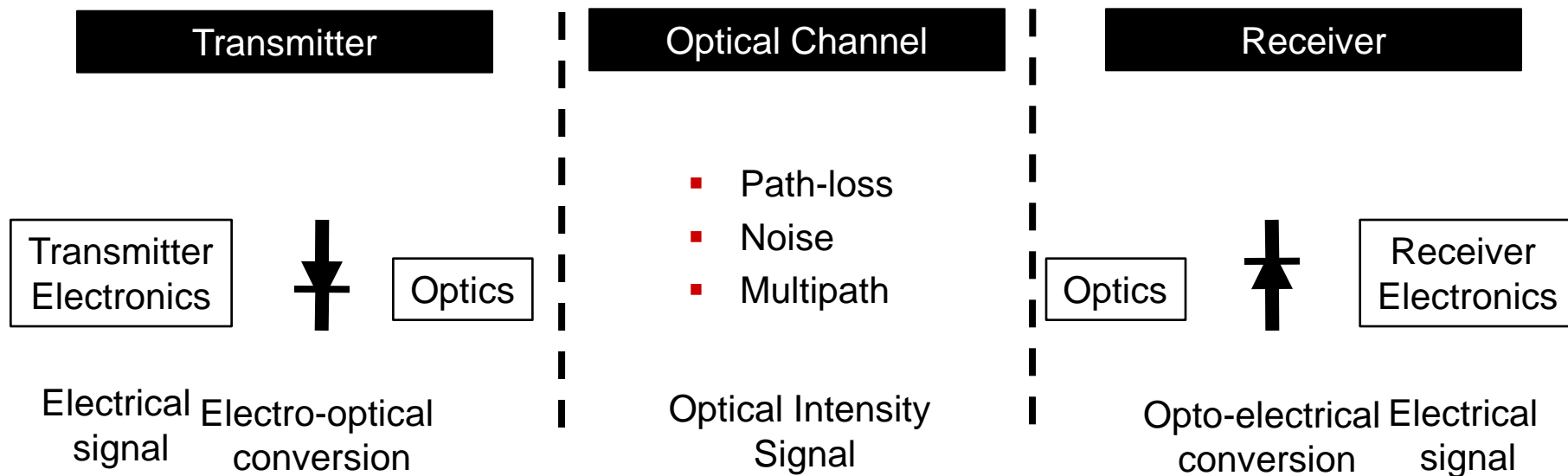

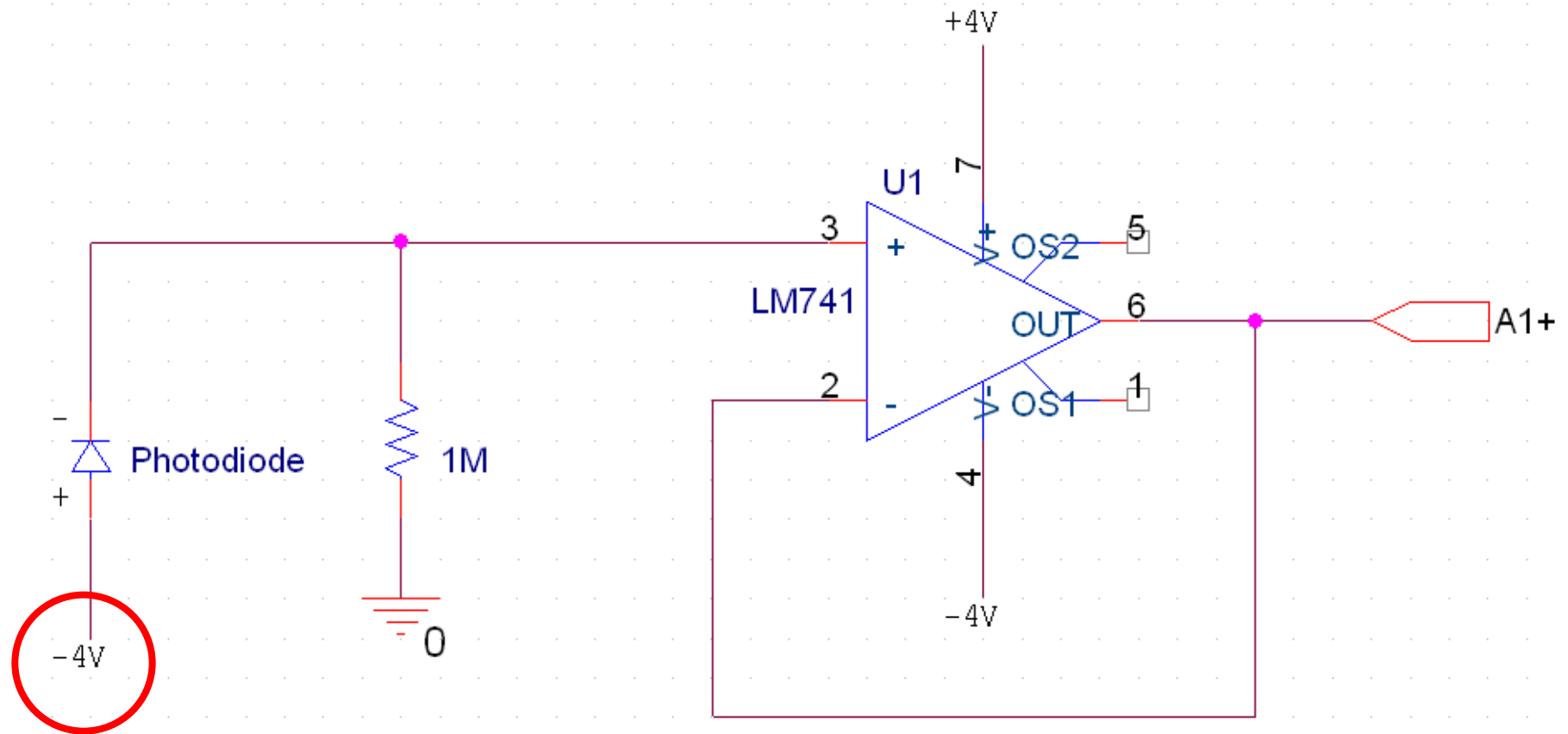

**Ambient light:** refers to sources of light that are already available naturally (e.g. the sun) or artificial (e.g. to light a room).

# Free Space Optical Communication

- Air, outer space, vacuum, ...



- Alternatives:
  - Optical fiber, transmission line
- Check out “heliograph” (wiki)

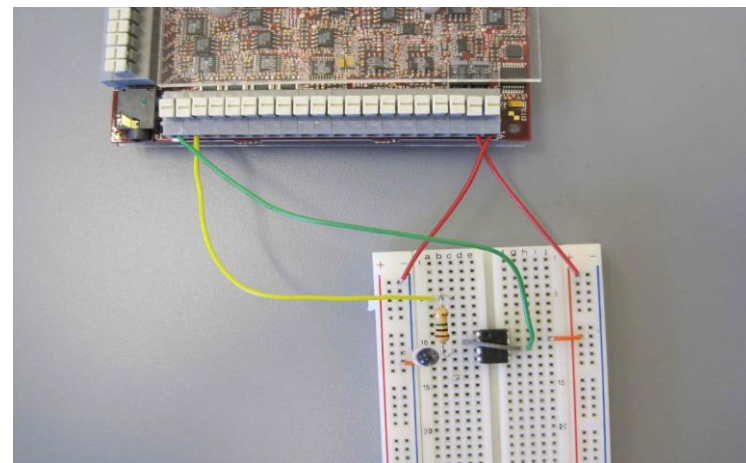
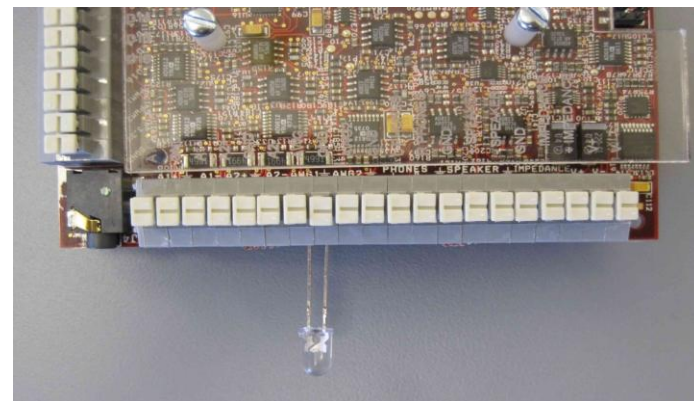

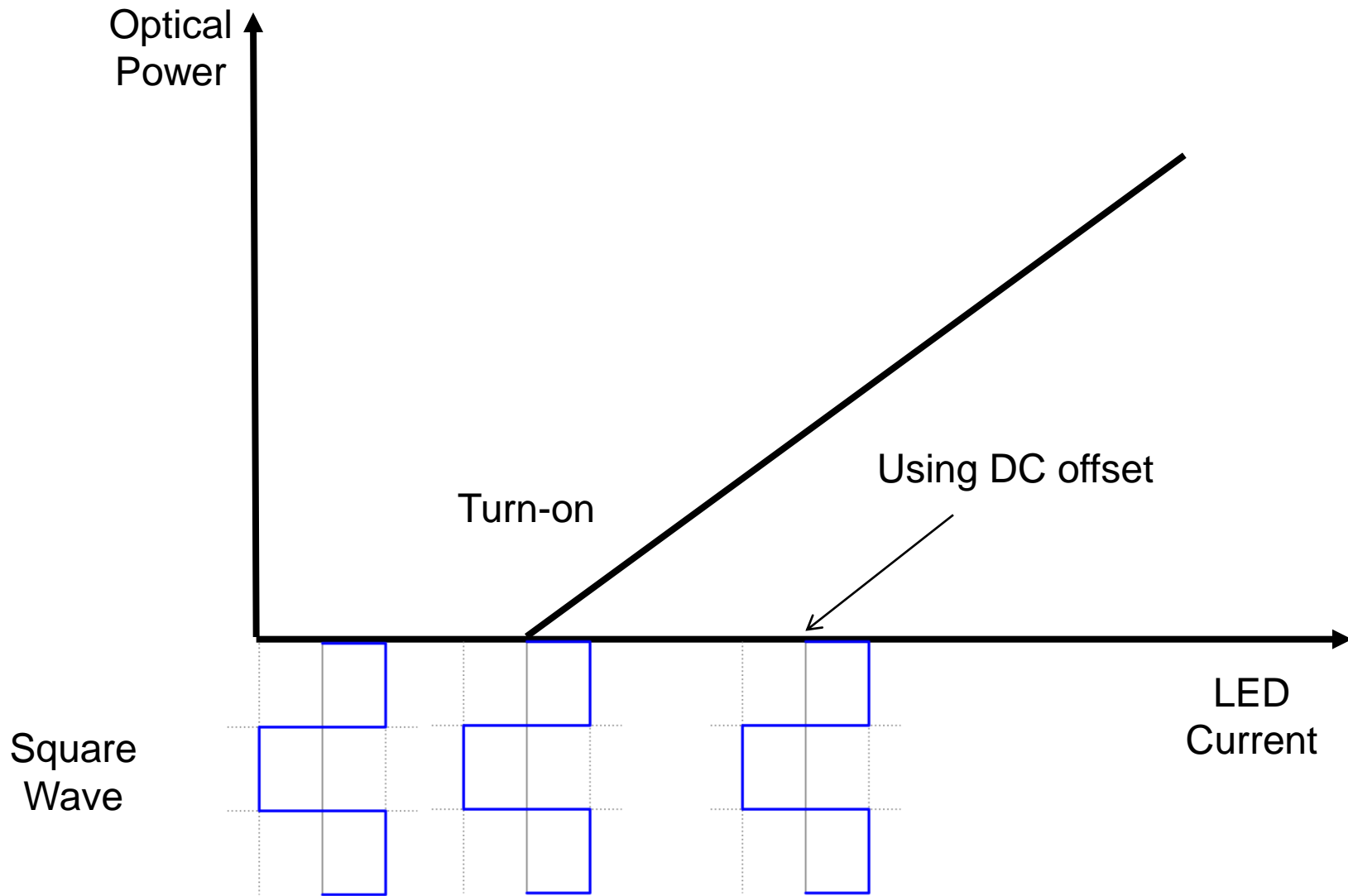

Square  
Wave

LED  
Current



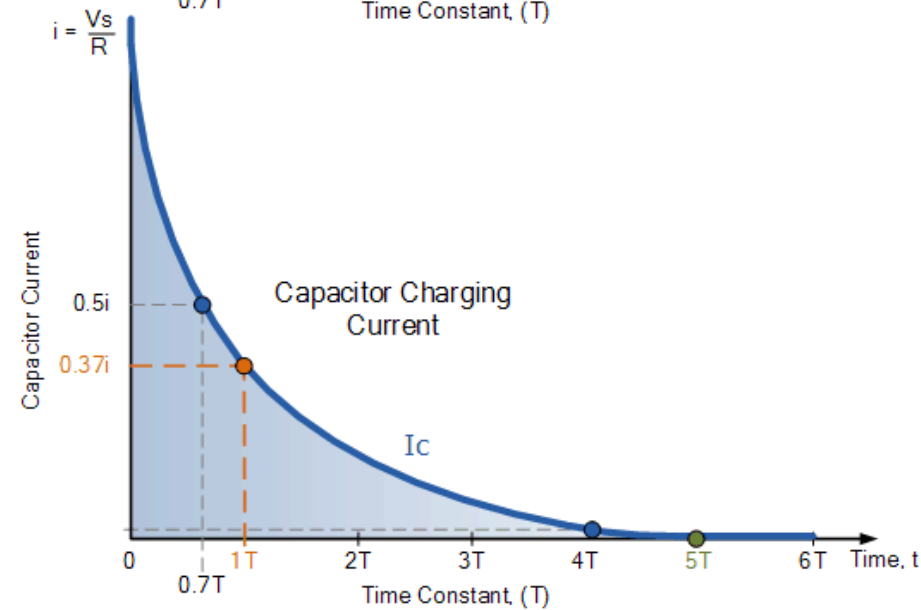
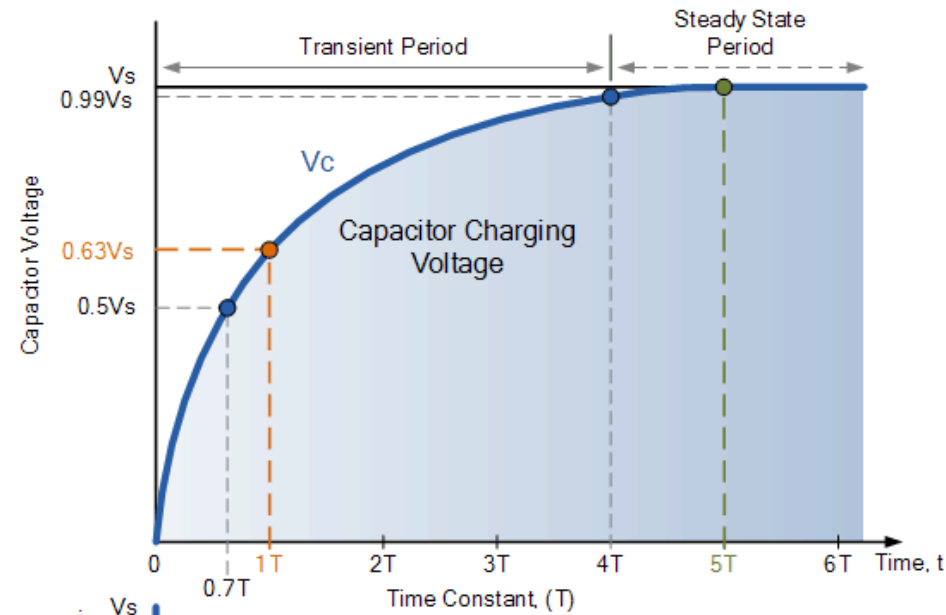
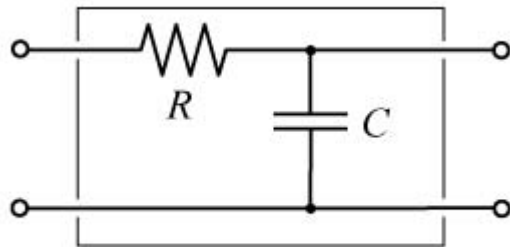
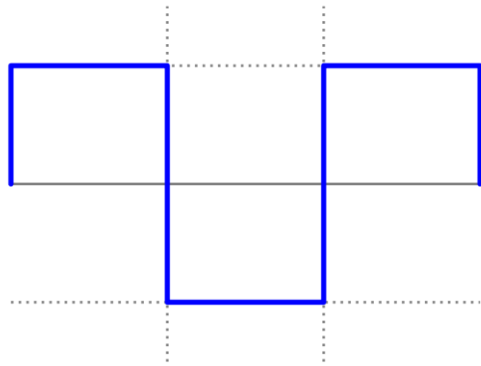

# Visible Light Spectrum, Spectrum Analyzer

- Simple spectrometer:
    - Using a CD
  - Spectrum analyzer:
    - Magnitude vs. frequency
    - What frequencies can you transmit well in your VLC setup?
      - Power, gain?
- Gain =  $10 \log (P_{out}/P_{in})$  dB**

