

# DERIVATION OF SOME PARAMETERS OF MYOELECTRIC SIGNALS RECORDED DURING SUSTAINED CONSTANT FORCE ISOMETRIC CONTRACTIONS

CARLO J. DE LUCA *and* EGBERT J. VANDYK

*From the Department of Orthopedic Surgery, Children's Hospital Medical Center, Harvard Medical School, Boston, Massachusetts 02115, and Liberty Mutual Insurance Co. Research Center, Hopkinton, Massachusetts 01748. Mr. van Dyk's present address is Nieuwe Laan 42-44, Vlaardingen, Netherlands.*

**ABSTRACT** Mathematical expressions are derived for some parameters of the myoelectric (ME) signal recorded during a constant force isometric contraction. The expressions are developed from a stochastic model for the motor-unit action-potential trains obtained from empirical results. The following parameters: (a) the mean rectified value, (b) the mean integrated rectified value, (c) the root-mean-square value, and (d) the power density spectrum are described as functions of contraction time and constant force of an isometric muscle contraction. The calculated parameters are compared to their corresponding empirically obtained measurements which have been reported in the literature. A discussion on the behavior of the parameters during increasing contraction time is presented. Synchronization of the motor-unit action-potential trains is shown to have a pronounced effect on the parameters of the myoelectric signal. This result should be considered when analyzing long records of myoelectric signals.

## INTRODUCTION

In electromyography, various parameters of the myoelectric (ME) signal have been used to describe the output and the state of the contracting skeletal muscle. Some of these parameters are: (a) the mean integrated rectified value, (b) the mean rectified value, (c) the root-mean-square (rms) value, and (d) the power density spectrum. The mean integrated rectified value has been the most commonly used parameter to date, but recently the other parameters have acquired prominence.

Various investigators have reported that the above parameters are time dependent even when the muscle output is kept constant, i.e., during a constant force isometric contraction. DeVries (1968) presented quantitative measurements indicating that the mean rectified value of the ME signal is time dependent; an observation which had been made qualitatively by many previous investigators. Kuroda et al. (1970) observed that the mean integrated rectified value is also time dependent. Kadefors et al. (1968) reported that the rms value increases with contraction time. Kaiser and Petersén

(1963) demonstrated that the frequency spectrum of the ME signal is time dependent during a sustained contraction.

The discovery of the relationships between some of the above mentioned parameters and the output or state of a contracting skeletal muscle has been a series of serendipitous occurrences. This paper will attempt to explain the validity of these relationships for ME signals recorded during a constant force isometric contraction.

Several investigators have attempted to formulate mathematical expressions for the ME signal (Bernshtein, 1967; Libkind, 1968; De Luca, 1968; Person and Libkind, 1970; Coggshall and Bekey, 1970; Lindström et al., 1970; Stern, 1971; Graupe et al., 1973; Kreifeldt and Yao, 1974; Brody et al., 1974). The recent work of Brody et al. (1974) was an extension of the modeling approach introduced by De Luca (1968). Of the above investigators only Libkind (1968) based his analysis on empirically derived information. De Luca and Forrest (1973) described an empirically derived model for the interpulse intervals of the motor-unit action-potential trains (MUAPTs) recorded during constant force isometric contractions. In this paper, equations of time-dependent parameters of the ME signal will be derived, based on the empirically derived model.

It is important to note that all the derived expressions are only applicable to the ME signal as it exists on the surface of the active muscle fibers. The expressions do not take into account the filtering effect of the ME signal caused by the muscle tissue, fascia, fat, skin, and recording electrode. The filtering effect assumes greater importance when surface electrodes are used to record the ME signal. The filtering function will only affect the motor-unit action-potential (MUAP). If the filtering function is known, the MUAP may be appropriately filtered before introducing it into the derived equations. Hence, the expressions remain valid.

## BACKGROUND

The ME signal is formed by a spatial-temporal summation of MUAPTs. Consider the MUAPT,  $u(t)$ , in Fig. 1. A MUAPT may be described by the shape of the MUAP,  $h(t)$ , and its firing rate  $\lambda(t, f)$ ; where  $f$  denotes the constant force value (De Luca and Forrest, 1973). The firing rate is defined as the average number of MUAPs per second in a MUAPT.

The correlation functions of time-dependent signals are functions of two time variables which will be denoted as  $t_a$  and  $t_b$ . Where  $t_a$  defines the time scale of the fixed signal and  $t_b$  that of the moved signal. De Luca (1975) has shown the autocorrelation function of a MUAPT may be expressed as:

$$R_{u, u_i}(t_a, t_b, f) = \int_0^\infty \lambda_i(\hat{t}, f) h_i(t_a - \hat{t}) d\hat{t} \int_0^\infty \lambda_i(\hat{t}, f) h_i(t_b - \hat{t}) d\hat{t} + \int_0^\infty \lambda_i(\hat{t}, f) h_i(t_a - \hat{t}) h_i(t_b - \hat{t}) d\hat{t}, \quad (1)$$

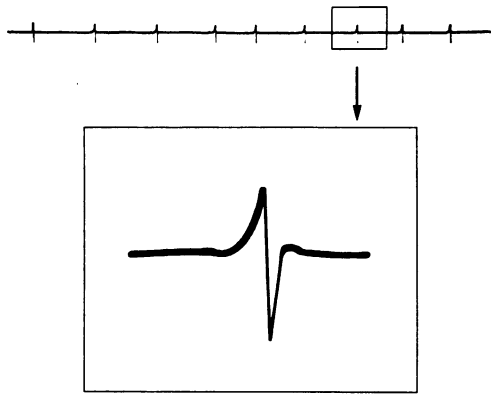

FIGURE 1

FIGURE 1 Motor-unit action-potential train recorded during a constant force isometric contraction.

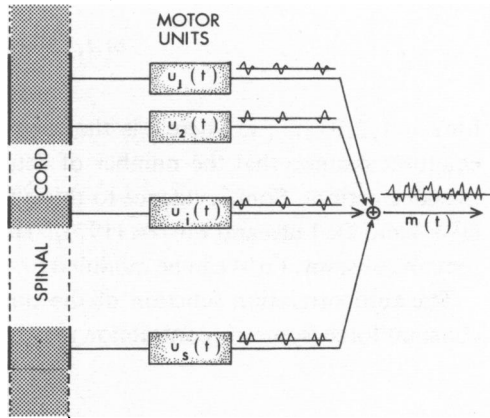

FIGURE 2

FIGURE 2 Schematic representation of myoelectric signal generation.

where  $\hat{t}$  is a dummy variable and the subscript  $i$  identifies the MUAPT,  $u_i(t, f)$ , from other MUAPTs in the same contraction. Similarly, the cross-correlation function of two statistically independent MUAPTs with firing rates  $\lambda_i(t, f) \neq \lambda_j(t, f)$  may be expressed as:

$$R_{u_i u_j}(t_a, t_b, f) = \int_0^\infty \lambda_i(\hat{t}, f) h_i(t_a - \hat{t}) d\hat{t} \int_0^\infty \lambda_j(\hat{t}, f) h_j(t_b - \hat{t}) d\hat{t}. \quad (2)$$

However, if the two MUAPTs fire in unison with  $\lambda_i(t, f) = \lambda_j(t, f)$  and the MUAPs of the two MUAPTs have a relative displacement,  $T_{ij}$ , less than the time duration of  $h_i(t)$  or  $h_j(t)$ , the cross-correlation function becomes

$$R_{u_i u_j}(t_a, t_b, f) = \int_0^\infty \lambda_i(\hat{t}, f) h_i(t_a - \hat{t}) d\hat{t} \int_0^\infty \lambda_i(\hat{t}, f) h_j(t_b - \hat{t}) d\hat{t} + \int_0^\infty \lambda_i(\hat{t}, f) h_i(t_a - \hat{t} \pm T_{ij}) h_j(t_b - \hat{t}) d\hat{t}. \quad (3)$$

In such a case, the MUAPTs are considered to be *synchronized*.

### SUPERPOSITION PROBLEM

An electrode affixed to or inserted into a muscle will record the spatial-temporal superposition of the individual MUAPTs that are active in the vicinity of the electrode. The superposition is illustrated in Fig. 2 and can be represented by

$$m(t, f) = \sum_{i=1}^s u_i(t, f) \quad (4)$$

for  $i = 1, 2, 3, \dots, s$ ; where  $s$  is the total number of MUAPTs present. The above equation assumes that the number of active MUAPTs remains constant throughout the contraction. Some evidence to this effect has been presented by Gilson and Mills (1941) and De Luca and Forrest (1973). However, if the number of MUAPTs does not remain constant, Eq. 4 can be modified by making  $s$  a function of time.

The autocorrelation function of the time-dependent ME signal recorded during a constant force isometric contraction may be expressed as:

$$R_{mm}(t_a, t_b, f) = \sum_{i=1}^s \sum_{j=1}^s R_{u_i u_j}(t_a, t_b, f). \quad (5)$$

Before summing the correlation functions, it is necessary to consider that some of the MUAPTs may be synchronized at some time throughout the contraction. The synchronous occurrence of MUAPTs has been observed by several investigators (Athanasios, 1923; Haas, 1927; Adrian, 1947; Buchthal and Madsen, 1950; Lippold et al., 1957; Zhukov and Zakharyants, 1959). The occurrence of synchronized MUAPTs is specially noticeable near the end of a prolonged muscle contraction.

If  $\nu$  number of MUAPTs in the ME signal are synchronized, the auto-correlation function of the ME signal may be obtained by substituting Eqs. 1 and 3 in Eq. 5, thus obtaining

$$\begin{aligned} R_{mm}(t_a, t_b, f) &= \sum_{i=1}^s \sum_{j=1}^s \int_0^\infty \lambda_i(\hat{t}, f) h_i(t_a - \hat{t}) d\hat{t} \int_0^\infty \lambda_j(\hat{t}, f) h_j(t_b - \hat{t}) d\hat{t} \\ &+ \sum_{i=1}^s \int_0^\infty \lambda_i(\hat{t}, f) h_i(t_a - \hat{t}) h_i(t_b - \hat{t}) d\hat{t} \\ &+ \sum_{i=1}^{\nu} \sum_{j=1}^{\nu} \int_0^\infty \lambda_i(\hat{t}, f) h_i(t_a - \hat{t} \pm T_{ij}) h_j(t_b - \hat{t}) d\hat{t}, \quad (6) \end{aligned}$$

with the restriction that  $\nu \leq s$ . The cross-covariance terms, the last group in the above equation, can be positive or negative, depending on the signs of the coinciding phases of any two MUAPS,  $h_i(t)$  and  $h_j(t)$ . Person and Mishin (1964) have indirectly verified that the cross-covariance term or the "synchronization term" increases the value of the autocorrelation function. They measured the cross-correlation functions of two ME signals recorded during a sustained constant force isometric contraction of the biceps brachii. The amplitude of the cross-correlation function of the ME signal from the final part of the contraction was 42% larger (at  $t = 0$ ) than that measured for the initial part of the contraction. (Measurements taken from Fig. 5 of Person and Mishin

[1964].) They attributed the increase in amplitude to synchronization of the MUAPTs. If no synchronized MUAPTs are present,  $\nu = 0$  and the cross-covariance terms of Eq. 6 do not exist.

Restricting the analysis to the case where  $t_a = t_b$ , i.e., considering the autocorrelation of the ME signal when there is no relative shift, Eq. 6 becomes:

$$\begin{aligned}
 R_{mm}(t, f) &= \left[ \sum_{i=1}^s \int_0^{\infty} \lambda_i(\hat{t}, f) h_i(t - \hat{t}) d\hat{t} \right]^2 + \sum_{i=1}^s \int_0^{\infty} \lambda_i(\hat{t}, f) h_i^2(t - \hat{t}) dt \\
 &+ \sum_{\substack{i=1 \\ i \neq j}}^{\nu} \sum_{j=1}^{\nu} \int_0^{\infty} \lambda_i(\hat{t}, f) h_i(t - \hat{t} \pm T_{ij}) h_j(t - \hat{t}) d\hat{t} \\
 &= [E\{m(t, f)\}]^2 + \sigma_m^2(t, f) \\
 &= (\text{mean})^2 + \text{variance} \\
 &= (\text{rms})^2 = \text{mean squared value.} \tag{7}
 \end{aligned}$$

In the above equations, the third expression with the double summation contains a total of  $\nu^2 - \nu$  terms.

De Luca (1975) has shown that in convolution expressions such as those in the above equation, the MUAP,  $h_i(t)$ , can be conveniently represented by a Dirac delta impulse multiplied by a constant that is equal to the area of the MUAP. For a MUAPT record of 45 s time duration, the error resulting from the Dirac delta approximations was less than 0.0086%. Hence, for practical purposes, the above equation may be reduced to:

$$R_{mm}(t, f) = \left[ \sum_{i=1}^s \lambda_i(t, f) \underline{h_i(t)} \right]^2 + \sum_{i=1}^s \lambda_i(t, f) \underline{h_i^2(t)} + \sum_{\substack{i=1 \\ i \neq j}}^{\nu} \sum_{j=1}^{\nu} \lambda_i(t, f) \underline{c_{ij}^2(t)}, \tag{8}$$

where

$$\underline{c_{ij}^2(t)} = \int_0^{\infty} h_i(t \pm T_{ij}) h_j(t) dt \quad \text{and} \quad \underline{h_i^2(t)} = \int_0^{\infty} h_i^2(t) dt.$$

The above equations can be used to calculate the mean rectified value, the mean integrated rectified value and the power density spectrum of the ME signal. However, in their present form they have a limited practical use for analyzing the time dependence of ME signals. The equations do not demonstrate the effect of the cancellation that results when positive and negative phases of different MUAPs superimpose.

Referring to Eqs. 4 and 5, it follows that:

$$E\{m(t, f)\} = E \left\{ \sum_{i=1}^s u_i(t, f) \right\} \quad \text{and} \tag{9}$$

$$E\{|m(t, f)|\} = E\left\{\left|\sum_{i=1}^s u_i(t, f)\right|\right\}. \quad (10)$$

Although the above equation is mathematically complete and correct, it is useful to express Eq. 10 as a summation of the absolute values of the individual MUAPTs. The cancellation resulting from superposition of opposite signed phases of MUAPs can only decrease the mean rectified value of the ME signal, hence

$$E\{|m(t, f)|\} \leq E\left\{\sum_{i=1}^s |u_i(t, f)|\right\}. \quad (11)$$

The equality in the previous equation can be reestablished by defining a nonpositive function

$$J(t, f) \leq 0$$

such that

$$E\{|m(t, f)|\} = E\left\{\sum_{i=1}^s |u_i(t, f)|\right\} + J(t, f). \quad (12)$$

If the MUAPTs are not correlated, the mean squared (MS) value of the ME signal is equal to the sum of the mean squared value of the MUAPTs:

$$MS\{m(t, f)\} = \sum_{i=1}^s MS\{u_i(t, f)\}. \quad (13)$$

When the MUAPTs are synchronized, they are correlated to some extent and

$$MS\{m(t, f)\} \neq \sum_{i=1}^s MS\{u_i(t, f)\}. \quad (14)$$

Therefore, in general the mean squared value may be expressed as:

$$MS\{m(t, f)\} = \sum_{i=1}^s MS\{u_i(t, f)\} + D(t, f). \quad (15)$$

The function  $D(t, f)$  can be positive or negative and is a measure of the amount of synchronization between the MUAPTs. From Eq. 7, it can be defined as

$$D(t, f) = \sum_{i=1}^s \sum_{j=1}^s \int_0^{\infty} \lambda_i(\hat{t}, f) h_i(t - \hat{t} \pm T_{ij}) h_j(t - \hat{t}) d\hat{t}. \quad (16)$$

## SOLUTIONS FOR THE PARAMETERS OF MYOELECTRIC SIGNALS

Eq. 8 can only be solved if all the individual firing rates,  $\lambda_i(t, f)$ , are known. In general, it is not possible to measure the firing rates from the ME signal. De Luca (1968, 1975) introduced the concept of the *generalized firing rate* which described the firing rate of a typical MUAP and is expressed as

$$\lambda(\tau, \phi) = \frac{1,000}{\beta(\tau, \phi) \Gamma[1 + (1/\kappa(\tau, \phi))] + \alpha} \text{ pulses/s,} \quad (17)$$

with

$$\begin{aligned} \kappa(\tau, \phi) &= 1.16 - 0.19\tau + 0.18\phi \\ \beta(\tau, \phi) &= \exp(4.60 + 0.67\tau - 1.16\phi) \text{ ms} \quad \text{for } 0 < \tau < 1, 0 < \phi < 1 \\ \alpha &= 3.89 \text{ ms} \end{aligned}$$

where  $\tau$  represents the normalized contraction time and  $\phi$  the constant force normalized with respect to the force of maximal voluntary contraction. A partial solution of Eq. 8 can be obtained by replacing the individual firing rates with the generalized firing rate.

### Mean Rectified Value

Disregarding the polarization potential of some recording electrodes, the ME signal has a mean value of zero. It is customary to rectify the ME signal before performing analysis. From Eqs. 7 and 8, it follows that the time-dependent mean value is:

$$E\{m(\tau, \phi)\} = \lambda(\tau, \phi) \sum_{i=1}^s \frac{h_i(\tau)}{s} = 0. \quad (18)$$

Full-wave rectification of the ME signal may be realized by taking the absolute value of  $h_i(\tau)$  and  $m(\tau, \phi)$ . It is not necessary to take the absolute value of  $\lambda(\tau, \phi)$  because this function is always positive in value. Hence, considering the superposition argument of Eq. 12, the time-dependent mean rectified value can be expressed as:

$$E\{|m(\tau, \phi)|\} = \lambda(\tau, \phi) \sum_{i=1}^s \frac{|h_i(\tau)|}{s} + J(\tau, \phi). \quad (19)$$

### Mean Integrated Rectified Value

It follows from Eq. 19 that the mean integrated rectified ME signal can be expressed as:

$$\begin{aligned} E\left\{\int_0^{\tau} |m(\tau, \phi)| \, d\tau\right\} &= \int_0^{\tau} E\{|m(\tau, \phi)|\} \, d\tau \\ &= \int_0^{\tau} \lambda(\tau, \phi) \sum_{i=1}^s \frac{|h_i(\tau)|}{s} \, d\tau + \int_0^{\tau} J(\tau, \phi) \, d\tau \end{aligned} \quad (20)$$

and if the number of MUAPTs,  $s$ , and the value of  $|h_i(\tau)|$  remain constant during a contraction

$$E \left\{ \int_0^{\tau} |m(\tau, \phi)| d\tau \right\} = \sum_{i=1}^s |h_i(\tau)| \int_0^{\tau} \lambda(\tau, \phi) d\tau + \int_0^{\tau} J(\tau, \phi) d\tau. \quad (21)$$

#### Root-Mean-Square Value

The autocorrelation function of Eq. 7 reduces to the mean squared value because the expected value of the ME signal is zero. Hence, the rms value can also be obtained from Eqs. 7 and 8:

$$\begin{aligned} RMS\{m(\tau, \phi)\} &= \sigma_m(\tau, \phi) \\ &= \lambda(\tau, \phi)^{1/2} \left[ \sum_{i=1}^s h_i^2(\tau) + \sum_{\substack{i=1 \\ i \neq j}}^v \sum_{j=1}^v c_{ij}^2(\tau) \right]^{1/2}. \end{aligned} \quad (22)$$

#### Power Density Spectrum

The time and constant-force dependent power density spectrum may be interpreted by the following approach. Consider the power density spectrum obtained from the ME signal over a small interval of the normalized contraction time,  $\Delta\tau$ . In this range, the function  $\lambda(\tau, \phi)$  may be represented by a constant value,  $\lambda_{\Delta\tau}$ . De Luca and Forrest (1973) have shown that  $\lambda(\tau, \phi)$  is a slowly decreasing monotonic function of time. With this restriction, it follows from the variance term in Eq. 7 that the power density spectrum of the ME signal in the time interval  $\Delta\tau$  may be expressed as:

$$S_{mm}(\omega, \Delta\tau, \phi) = \lambda_{\Delta\tau} \left( \sum_{i=1}^s |H_i(\omega)|^2 + \sum_{\substack{i=1 \\ i \neq j}}^v \sum_{j=1}^v |C_{ij}(\omega)|^2 \right) \quad (23)$$

where  $|H_i(\omega)|^2 = H_i(\omega)H_i^*(\omega)$ ,  $|C_{ij}(\omega)|^2 = C_{ij}(\omega)C_{ij}^*(\omega)$ , and  $H_i(\omega)$  and  $C_{ij}(\omega)$  are the Fourier transforms of the corresponding functions,  $h_i(\tau)$  and  $c_{ij}(\tau)$ .

The equations of the first three parameters can be solved if the areas of  $h_i(\tau)$  and  $c_{ij}^2(\tau)$  are known. If they are not known, normalized solutions can be obtained if the areas remain constant during the duration of a contraction. Reports of both increase and decrease of the amplitude of the MUAP can be found in the literature. Knowlton et al. (1951) and Stålberg (1966) reported an increase in the amplitude with increasing contraction time. On the other hand, several investigators (Lindsley, 1935; Seyffarth, 1940; Bigland and Lippold, 1954; Lindquist, 1959; Lippold et al., 1960; De Luca and Forrest, 1973) have reported that the amplitude decreases with increasing contraction time. De Luca and Forrest (1973) also stated that the time duration of the MUAP has a tendency to increase with contraction time. Lindström et al. (1970) postulated that variations in the shape of a MUAP could be attributed to a decreasing



conduction velocity of the muscle fibers during a sustained contraction. If, indeed, the amplitude decreases and the time duration increases, then the area of  $h_i(\tau)$  and  $c_{ij}^2(\tau)$  does not vary substantially with contraction time.

As a first order approximation, assume that the areas remain constant and, as previously stated, the number of active MUAPTs remains constant. Eqs. 19 and 21 will reduce to

$$E\{|m(\tau, \phi)|\} = K_1 \lambda(\tau, \phi) + J(\tau, \phi) \quad (24)$$

$$E \left\{ \int_0^\tau |m(\tau, \phi)| d\tau \right\} = K_1 \int_0^\tau \lambda(\tau, \phi) d\tau + \int_0^\tau J(\tau, \phi) d\tau \quad (25)$$

where

$$K_1 = \sum_{i=1}^s |h_i(\tau)| = \text{constant.}$$

For the sake of simplification, consider the rms value under the restriction that the number of synchronized MUAPTs remains constant. The rms value will reduce to:

$$RMS\{m(\tau, \phi)\} = K_2 \lambda(\tau, \phi)^{1/2},$$

where

$$K_2 = \left[ \sum_{i=1}^s h_i^2(\tau) + \sum_{i=1}^v \sum_{\substack{j=1 \\ i \neq j}}^v c_{ij}^2(\tau) \right]^{1/2} = \text{constant.} \quad (26)$$

Plots of Eqs. 24–26 can be seen in Figs. 3–6. Fig. 3 shows the mean rectified value as a function of normalized contraction time and normalized force values (with respect to maximal contraction force) of 0.95, 0.9, 0.8, 0.7, 0.6, 0.5, 0.4, 0.3, 0.2, 0.1, and 0.05. The curves of Figs. 4–6 were obtained by normalizing the 11 curves of the different force levels with respect to each other. In Fig. 5, the plots were normalized with respect to the value at  $\tau = 1$ . In Figs. 4 and 6, the plots were normalized with respect to the value at  $\tau = 0$ .

It must be noted that the plot of the rms value in Fig. 4 has limited physical significance. The curves were calculated with the additional constraint that the number of synchronized MUAPTs is constant. Lippold et al. (1957) have presented evidence that an increasing number of MUAPTs have a tendency to synchronize as the time of a sustained contraction increases.

## DISCUSSION

The Eqs. 19–23 developed for the time-dependent parameters of the ME signal recorded during a constant force isometric contraction reveal that the parameters are dependent on: (a) the firing rate,  $\lambda(t, f)$ , of the motor units, (b) the number of motor unit action-potential trains (MUAPTs) comprising the ME signal, (c) the area or shape

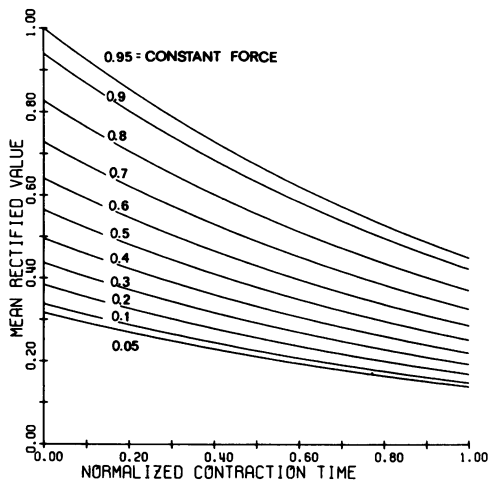

FIGURE 3

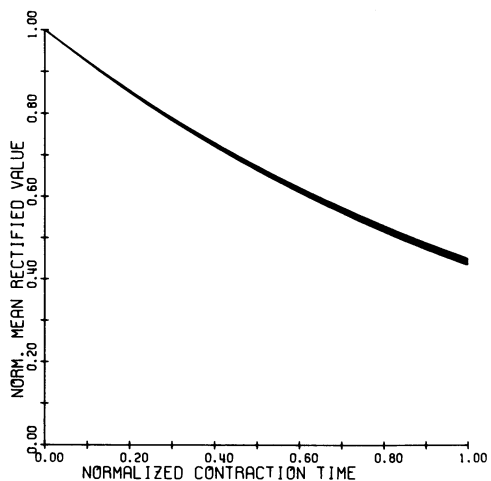

FIGURE 4

FIGURE 3 Mean rectified value of the myoelectric signal as a function of normalized time. All the values are normalized with respect to the point at  $\tau = 0, \phi = 0.95$ .

FIGURE 4 The normalized mean rectified value of the myoelectric signal as a function of normalized contraction time. 11 plots for normalized constant force values of 0.95, 0.90, 0.80, ..., 0.1, 0.05 are present.

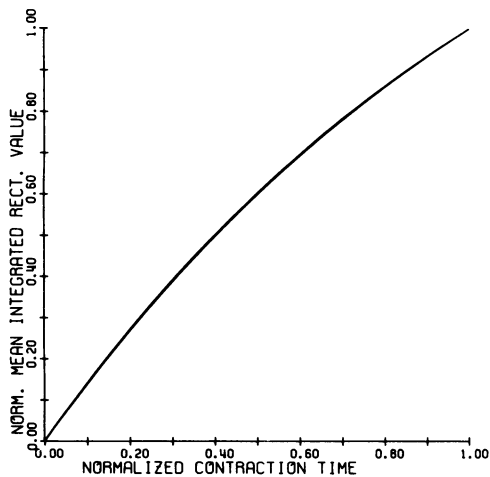

FIGURE 5

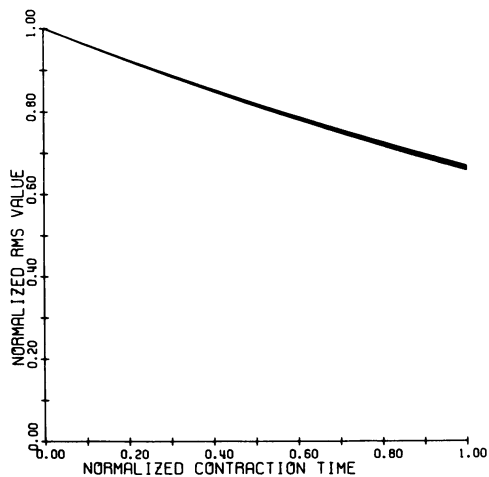

FIGURE 6

FIGURE 5 The normalized mean rectified integrated value of the myoelectric signal as a function of normalized contraction time. 11 plots for normalized constant force values of 0.95, 0.90, 0.80, ..., 0.1, 0.05 are present.

FIGURE 6 The normalized rms value of the myoelectric signal as a function of normalized contraction time. 11 plots for normalized constant force values of 0.95, 0.90, 0.80, ..., 0.10, 0.05 are present.

of the MUAP, and (*d*) the number of synchronized MUAPTs. Evidence based on previous work has been presented throughout this paper to indicate that during a sustained constant force isometric contraction: (*a*) the magnitude of  $\lambda(t, f)$  decreases, (*b*) the amplitude of a MUAP tends to decrease, whereas, its time duration increases, and (*c*) the number of synchronized MUAPTs increases. It has been postulated with some evidence (Gilson and Mills, 1941, and De Luca and Forrest, 1973) that the number of active MUAPTs remains constant throughout a constant force isometric contraction. If future experimentation disproves this postulation, the effect of a varying number of active MUAPTs on the ME signal parameters must be considered. The mathematical developments in this paper can easily incorporate such a modification.

The opposing effects of the decreasing amplitude and increasing time duration of a MUAP tend to minimize any change in the area of a MUAP during a sustained contraction. Hence, the time dependence of the mean rectified value, the mean integrated rectified value, and the rms value may be mainly attributed to the time dependence of the firing rate,  $\lambda(t, f)$ , and the number of synchronized MUAPTs that would affect the value of the  $J(t, f)$  and  $D(t, f)$  functions. The power density spectrum is the most complicated parameter and will be affected by the firing rate, the shape of the MUAP and the synchronization of MUAPTs. The firing rate of MUAPTs decreases with contraction time during an isometric constant force contraction (De Luca and Forrest, 1973; Gydikov and Kosarov, 1974; Person and Kudina, 1972; Tanji and Kato, 1972). Therefore, the firing rate will decrease the value of the ME signal parameters as a function of time. The effect of synchronization is more difficult to interpret. The following three possibilities will occur:

(*a*) The synchronized pulses do not overlap with no cancellation of the pulses occurring: (*i*) The function  $J(t, f) = 0$ . The mean rectified and the integrated mean rectified values will increase. (*ii*) The function  $D(t, f) = 0$ . The rms value and power density spectrum remain unchanged.

(*b*) The synchronized pulses overlap such that the  $c_{ij}^2(t)$  are predominantly negative, and an additional amount of cancellation is present: (*i*) The function  $J(t, f) < 0$ . The mean rectified and the integrated mean rectified values will decrease. (*ii*) The function  $D(t, f) < 0$ . The rms value and the power density spectrum will decrease.

(*c*) The synchronized pulses overlap such that the  $c_{ij}^2(t)$  are predominantly positive and an additional amount of cancellation is present: (*i*) The function  $J(t, f) < 0$ . The mean rectified and integrated mean rectified values will decrease. (*ii*) The function  $D(t, f) > 0$ . The rms value and the power density spectrum will increase.

The above possibilities indicate that synchronization may increase or decrease the ME signal parameters. The actual effect must be verified by empirical measurements. In all cases, synchronization effects the ME signal parameters. This outcome may provide a measure for the degree of synchronization present in the ME signal. If synchronization is considered to be a demonstration of "muscle fatigue," (Grimby et al., 1974) then it may be possible to obtain an indirect objective measure of "muscle fatigue."

The plots of Figs. 3-6 only demonstrate the effect of the firing rate. It can be seen that the mean rectified value, the mean integrated rectified value and the rms value of the ME signal are not dependent on the constant force level of the muscle contraction when they are plotted on normalized amplitude and contraction-time scales. In the latter three figures, the variation of the lines comprising the plots is symmetrical about a line plotted for  $\phi = 0.45$ . For the mean rectified value, the maximum deviation from the line representing  $\phi = 0.45$  is  $\pm 1.75\%$ ; for the mean integrated rectified value, the maximum deviation is  $\pm 0.35\%$ ; and for the rms value,  $\pm 0.87\%$ . At  $\tau = 1$ , the mean rectified value decreases to 44.2% of the value at  $\tau = 0$ ; and the rms value decreases to 66.5% of the value at  $\tau = 0$ .

As mentioned in the introduction, the derived expressions are only applicable to the ME signal as it exists on the surface of active muscle fibers. Hence, the derived equations should be compared to empirically obtained parameters of ME signals recorded with closely placed indwelling electrodes. In addition, the plots of Figs. 3-6 were obtained with some constraint. Most of the time dependent ME parameters that have been reported in the literature have been obtained from ME signals recorded with surface electrodes. Hence, any comparison between the calculated value of the parameters obtained by other investigators should be made with great caution. DeVries (1968), Kadefors et al. (1968), and Kuroda et al. (1970) have reported that the parameters of ME signals recorded with surface electrodes during a constant force isometric contraction increase with contraction time. It is tempting to interpret this observation to mean that synchronization increases the value of the parameters. However, there is yet another phenomenon to consider when surface recordings are analyzed. The ME signal must propagate through muscle, fascia, fat, and skin tissue. These tissues act as a low-pass filter with a break frequency of approximately 100 Hz (Kadefors et al., 1968; De Luca, 1968). Kadefors et al. (1968) presented evidence that during a sustained constant force isometric contraction, the low frequency content of the ME signal increases and the high frequency content decreases as the contraction progresses. Hence, with increasing contraction time, a surface electrode would see a larger ME signal and the value of the parameters increases.

In a study about to be completed, Stulen (1975) has demonstrated that for ME signals recorded with indwelling bipolar needle electrodes during a sustained constant force isometric contraction, the empirically obtained parameters have similar characteristics to those shown in Figs. 4-6. The result of this recent study will be reported in a separate publication.

We would like to thank Mr. F. B. Stulen and Mr. R. LeFever for the suggestions they made in proofreading the manuscript.

This work was supported in part by a grant from the Social and Rehabilitation Service, Rehabilitation Service Administration, Department of Health, Education and Welfare (no. 23-P-55854), in part by the Liberty Mutual Insurance Company Research Center, and in part by research funds from Queen's University, Kingston, Ontario, Canada.

*Received for publication 10 February 1975.*

## REFERENCES

- ADRIAN, E. D. 1947. General principles of nervous activity. *Brain*. 70:1.
- ATHANASIU, J. 1923. L'energie nerveuse motrice electroneurogramme. *J. Physiol. Pathol. Gen.* 21:15.
- BERNSHTEIN, V. M. 1967. Statistical parameters of the electric signal of a muscle model. *Biophysics (Engl. Transl. Biofiz.)*. 12:693.
- BGLAND, B., and O. C. J. LIPPOLD. 1954. Motor unit activity in the voluntary contraction of human muscle. *J. Physiol.* 125:322.
- BRODY, G., R. BALASUBRAMANIAN, and R. N. SCOTT. 1974. A model for myoelectric signal generation. *Med. Biol. Eng.* 12:29.
- BUCHTHAL, F., and E. E. MADSEN. 1950. Synchronous activity in normal and atrophic muscle. *EEG Clin. Neurophysiol.* 2:425.
- COGGSHALL, J. C., and G. A. BEKEY. 1970. A stochastic model of skeletal muscle based on motor unit properties. *Math. Biosci.* 7:405.
- DE LUCA, C. J. 1968. Myoelectric Analysis of Isometric Contractions of the Human Biceps Brachii. M.Sc. Thesis, University of New Brunswick, Fredericton, N.B., Canada.
- DE LUCA, C. J. 1975. A model for a motor unit train recorded during constant force contractions. *Biol. Cybern.* 19:159.
- DE LUCA, C. J., and W. J. FORREST. 1973. Some properties of motor unit action potential trains recorded during constant force isometric contractions in man. *Kybernetik*. 12(3):160.
- DEVRIES, H. A. 1968. Method for evaluation of muscle fatigue and endurance from electromyographic fatigue curves. *Am. J. Phys. Med.* 47:125.
- GILSON, A. S., JR., and W. B. MILLS. 1941. Activities of single motor units in man during slight voluntary efforts. *Am. J. Physiol.* 133:658.
- GRAUPE, D., W. K. CLINE, and T. K. KAPLAN. 1973. Stochastic analysis of EMG signal for multiple functional prosthesis control purposes. Proceedings of the 1973 Carnahan Conference on Electronic Prosthetics. 90.
- GRIMBY, L., J. HANNERZ, and T. RANLUND. 1974. Disturbances in the voluntary recruitment order of anterior tibial motor units in spastic paraparesis upon fatigue. *J. Neurol. Neurosurg. Psychiatry*. 37:40.
- GYDIKOV, A., and D. KOSAROV. 1974. Some features of different motor units in human biceps brachii. *Pfuegers Arch. Gesamte. Physiol.* 347:75.
- HAAS, E. 1972. Untersuchungen über Objektive und Subjektive Ermüdung bei Willkürlichen Kontraktionen. *Pfuegers Arch. Gesamte. Physiol.* 218:386.
- KADEFORS, R., E. KAISER, and I. PETERSÉN. 1968. Dynamic spectrum analysis of myo-potentials with special reference to muscle fatigue. *Electromyography*. 8:39.
- KAISER, E., and I. PETERSEN. 1963. Frequency analysis of muscle action potentials during tetanic contraction. *Electromyography*. 3:5.
- KNOWLTON, G. C., R. C. BENNETT, R. MCCLURE. 1951. Electromyography of fatigue. *Arch. Phys. Med.* 32:648.
- KREIFELDT, J. G., and S. YAO. 1974. A signal-to-noise investigation of nonlinear electromyographic processes. *IEEE Trans. Bio-Med. Eng.* 21:298.
- KURODA, E., V. KLISSOURAS, and J. H. MILSUM. 1970. Electrical and metabolic activities and fatigue in human isometric contraction. *J. Appl. Physiol.* 29:358.
- LIBKIND, M. S. 1968. II. Modelling of Interference Bioelectrical Activity. *Biofizika*. 13:685.
- LINDQUIST, C. 1959. The motor unit potential in severely paretic muscles after acute anterior poliomyelitis. *Acta Psychiatr. Neurol. Scand. Suppl.* 131. 34.
- LINDSLEY, D. B. 1935. Electrical activity of human motor units during voluntary contraction. *Am. J. Physiol.* 114:90.
- LINDSTRÖM, L., R. MAGNUSSON, and I. PETERSÉN. 1970. Muscular fatigue and action potential conduction velocity changes studied with frequency analysis of EMG signals. *Electromyography*. 10:341.
- LIPPOLD, O. C. J., J. W. T. REDFEARN, and J. VUČO. 1957. The rhythmical activity of groups of motor units in the voluntary contraction of muscle. *J. Physiol.* 135:473.
- LIPPOLD, O. C. J., J. W. T. REDFEARN, and J. VUČO. 1960. The electromyography of fatigue. *Ergonomics*. 3:121.

- PERSON, R. S., and L. P. KUDINA. 1972. Discharge frequency and discharge pattern of human motor units during voluntary contraction of muscles. *Electroencephalogr. Clin. Neurophysiol.* 32:471.
- PERSON, R. S., and M. S. LIBKIND. 1970. Stimulation of electromyograms showing interference patterns. *EEG Clin. Neurophysiol.* 29:625.
- PERSON, R. S., and L. W. MISHIN. 1964. Auto- and cross-correlation analysis of the electrical activity of muscles. *Med. Electron. Biol. Eng.* 2:155.
- SEYFFARTH, H. 1940. The behaviour of motor units in voluntary contraction. University of Oslo. Jacob DybWads, Forlag Oslo, Norway.
- STÅLBERG, E. 1966. Propagation velocity in human muscle fibers in situ. *Acta Physiol. Scand. Suppl.* 287:70.
- STERN, M. M. 1971. A model that relates low frequency EMG power to fluctuations in the number of active motor units: application to local muscle fatigue. Ph.D. Dissertation. University of Michigan, Ann Arbor.
- STULEN, F. B. 1975. Analysis of the time dependence of myoelectric signal parameters based on a stochastic model of motor unit properties. M.S. Thesis, Massachusetts Institute of Technology, Cambridge.
- TANJI, J., and M. KATO. 1972. Discharges of single motor units at voluntary contraction of abductor digiti minimi muscle in man. *Brain Res.* 45:590.
- ZHUKOV, E. K., and J. Z. ZAKHARYANTS. 1959. Synchronized rhythm of action potentials during muscle activity in man. *Fiziol. Zh. (Kiev).* 45:1053.