

GCC VAT: THE INTRA-GULF TRADE PROBLEM

Boston University School of Law
Law & Economics Working Paper No. 17-03

Richard T. Ainsworth
Boston University School of Law

Musaad Alwohaibi
University of Florida, Fredric G. Levin College of Law

This paper can be downloaded without charge at:

<http://www.bu.edu/law/faculty-scholarship/working-paper-series/>

GCC VAT: THE INTRA-GULF TRADE PROBLEM

Richard T. Ainsworth
Musaad Alwohaibi

It seems reasonably clear that by January 1, 2018¹ events will be set in motion for the adoption of a community-wide 5% value added tax (VAT) in the six Member States of the Gulf Cooperation Council (GCC).² Per agreement of the Council, once two Members institute a VAT that conforms to the GCC's agreed Framework the remaining members must follow suit within one year's time.³ Both Saudi Arabia⁴ and the UAE⁵ indicate that they will adopt conforming VATs by January 1, 2018.

The rough outlines of the Arabian VATs are being publicly discussed. These conversations presently come with a lot of assumptions about what will be in the Framework and the actual statutes.⁶ At this time, however, granular details are lacking.

¹ UAE Ministry of Finance, *VAT: VAT Questions*, (accessed August 5, 2016) available at: <https://www.mof.gov.ae/En/budget/Pages/VATQuestions.aspx>

² The member state of the Gulf Cooperation Council are: Bahrain, Kuwait, Oman, Qatar, Saudi Arabia and the United Arab Emirates.

³ Staff writers, *VAT to be Introduced in UAE in 2018 @ 3-5%: Official*, Emirates 24/7 (January 19, 2016) (citing the Undersecretary at the Ministry of Finance, Younis Haji Al Khoori who indicated that the first two GCC countries to introduce a VAT and present them to the GCC will determine the timing of the tax for the whole GCC in comments at the first meeting of the Under-Secretaries of the Arab Ministries of Finance, organized by the UAE MoF in cooperation with the Arab Monetary Fund) available at: <http://www.emirates247.com/news/emirates/vat-to-be-introduced-in-uae-in-2018-3-5-official-2016-01-14-1.617264>.

⁴ The Saudi Minister of Finance, Ibrahim Al-Assaf confirmed after a meeting of the Secretariat of the GCC that the Convention on Value Added Tax is complete and ready for application, and that Saudi Arabia expects to have a VAT in place by January 1, 2018. *Gulf Finance Ministers Approve the Final Version of the Convention on Value-Added and their Application in 2018*, AAWSAT (May 4, 2016) available at: <http://aawsat.com/home/article/631231/%D9%88%D8%B2%D8%B1%D8%A7%D8%A1-%D9%85%D8%A7%D9%84%D9%8A%D8%A9-%D8%A7%D9%84%D8%AE%D9%84%D9%8A%D8%AC-%D9%8A%D9%82%D8%B1%D9%88%D9%86-%D8%A7%D9%84%D8%B5%D9%8A%D8%BA%D8%A9-%D8%A7%D9%84%D9%86%D9%87%D8%A7%D8%A6%D9%8A%D8%A9-%D9%84%D8%A7%D8%AA%D9%81%D8%A7%D9%82%D9%8A%D8%A9-%D8%A7%D9%84%D9%82%D9%8A%D9%85%D8%A9-%D8%A7%D9%84%D9%85%D8%B6%D8%A7%D9%81%D8%A9-%D9%88%D8%AA%D8%B7%D8%A8%D9%8A%D9%82%D9%87%D8%A7-%D9%81%D9%8A>

⁵ Abdul Basit, *VAT will be a source of revenue in UAE*, KHALEEJ TIMES (July 19, 2016) available at: <http://khaleejtimes.com/nation/general/vat-will-be-a-source-of-income>

⁶ It is important to note that no GCC state has enacted a VAT law as of August 2016, nor is there a published GCC framework into which all GCC VATs must "fit." Consider in this regard, the KPMG, *Update of VAT proposals in Oman and across the GCC* (June 2016) available at: <https://home.kpmg.com/om/en/home/insights/2016/06/update-on-proposed-vat-in-oman-and-gcc.html>. The KPMG discussion is typical of current analysis in this area. It is largely "... based on similar agreements in other region in particular the European Union ... " and as a result it is really less of a revelatory discussion of a specific Arabian VAT than it is a set of observations about what "... the GCC VAT agreement *could include*, amongst other things, the scope of VAT (both goods and services), place and time of supply rules, valuation rules, and rules for getting an input VAT deduction." (emphasis added). Fahad Al Ghadani & K. Rejimon, *Oman Moving towards 5 percent Value Added Tax*, TIMES OF OMAN (August 6, 2016) available

The GCC's Framework document is expected to be published by the end of October 2016.⁷

Nevertheless, there are more than enough solid statements from various Finance Ministers to begin to offer substantive commentary. One of the clearest, consistently placed observations is that the Arabian VATs will be destination-based and modeled on a European credit-invoice design.⁸ Intra-Gulf business-to-business (B2B) transactions will be effectively zero-rated by the supplier, and the buyer's VAT will be directed to the destination jurisdiction. It is not clear if the mechanism directing this deposit to the destination jurisdiction will be through *customs agents*, a buyer's *reverse charge* procedure as in the EU, or a seller's remission of VAT directly (or indirectly) to the foreign treasury through a *one-stop-shop*. The lack of clarity on this final element does not detract from the "true ring" of the other observations.

This paper takes these observations as a given and drills down to the next level. How (exactly) will (or should) the Arabian VATs intra-Gulf zero-rating in goods be implemented? Will the same mechanism be used for intra-Gulf and extra-Gulf tradable services? There is neither public commentary, nor private statements on the issues raised by this implementation question, but the warning flags are up. The procedures adopted by the EU to implement its zero rating/ reverse charge mechanism have been the core structural problem underpinning the EU's struggle with MTIC and MTEC frauds.⁹ Will the GCC follow suit, or have they found another/ better way? There are indications that the GCC may just have found a better way forward, and it will be implemented.

There are two traditional approaches to crafting statute that will put in place a zero rate regime for cross-border transactions within a community – (a) the *customs-controlled* approach, and (b) two *accounting-controlled* approaches (a *reverse charge* or a *one-stop-shop*). Currently there is (c) a *technology-controlled (real-time)* implementation for each of these regimes. This paper contends that the Arabian VATs

at: <http://timesofoman.com/article/78531/Oman/Government/Oman-plans-five-per-cent-VAT-by-2018-or-in-2019>

⁷ Pierre Arman from Thomson Reuters indicating in advance of the GCC VAT Forum that the GCC Framework will be published near the end of October 2016. Nauman Asif Mian, *Experts in UAE look at benefits of VAT*, MSN NEWS, available at: <http://www.msn.com/en-ae/news/uae/experts-in-uae-look-at-benefits-of-vat/ar-BBw1zPk?li=BBqrVLO>

⁸ This was the recommendation of two sets of technical reports: Ehtisham Ahmad, Dale Chua, Anna Ivanova, A.M. Abdel-Rahman & Satya Poddar *GCC Options for Indirect taxation*, Report to the GCC Secretariat (2006); Ehtisham Ahmad, A.M. Abdel-Rahman, Rick Matthews, Satya Poddar & Christopher Waerzeggers, *Indirect Taxation for the Common Market*, Report to the GCC Secretariat (2008). See also the meeting of the GCC Secretariat where the VAT is discussed as a destination tax based on the credit invoice system.

⁹ MTIC (missing trader intra-community) fraud occurs in goods and tradable services when supplies are made among businesses across internal borders. Because supplies are made without VAT, the buyer sells on, collects VAT on the re-sale but does not report the transaction. He is a "missing trader." MTEC (missing trader extra-community) fraud occurs in tradable services that are "imported" from third countries. In B2B transactions the buyer will purchase the service, re-sell within the community, collect VAT, and not report the transaction. MTEC is common in CO2 permits and VoIP. For a discussion of MTIC and MTEC see: Richard T. Ainsworth, *VAT Fraud: The Tradable Services Problem* 61 TAX NOTES INTERNATIONAL 217 (January 17, 2011).

will benefit from history, and they are ideally positioned to show the VAT community how to use *real-time technology* to solve some of its most difficult cross-border trade problems. A common example will assist throughout this paper.

COMMON EXAMPLE

Assume three jewelry makers (business owners), “A” a resident of Saudi Arabia, “B” a resident of the UAE, and “C” a resident of the UK, walk into a shop in Riyadh, Saudi Arabia to purchase 25 princess diamonds for (SAR) 1.5 million.¹⁰ Each businessman is a very successful jeweler with an annual turnover in excess of (SAR) 4 million. “A” and “B” are required to file VAT returns in Saudi Arabia, and the UAE respectively.¹¹ “C” files in the UK. The VAT in both Saudi Arabia and the UAE is at 5%. In the UK the VAT is 20%. Loose diamonds are subject to VAT in all three jurisdictions.

At the conclusion of each sale, each jewelry maker receives a small bag with loose diamonds in it and pays entirely in cash. Each jeweler returns to his respective business location to make 25 diamond rings: “A” on a side street in Riyadh, Saudi Arabia (a short walk away), “B” to the UAE (a drive away by auto over land through the Saudi/UAE border crossing), and “C” to the UK (a commercial flight to London).

“A” is not engaged in an intra-Gulf transaction. “A” is included in the common example because he is both the standard for a “fair” assessment of the VAT, and he is a willing buyer of diamonds in Saudi Arabia who might be persuaded to purchase them for less if “B” or “C” could secure them VAT-free.

Tax policy standard. The Arabian VAT should be neutral as to “A”, “B”, and “C”. The law should not preference one jewelry maker over another. At the end of the day, “A’s” domestic purchase should not be advantaged, or disadvantaged relative to “B’s” purchase. If the UK VAT treats “C” differently *in the UK*, that should be of no concern to the Arabian VATs just as long as the portions of the transaction under Saudi control are treated the same as comparable parts of the transactions for “A” and “B”.

The Arabian VAT should also be neutral with respect to in-person transactions versus distance transactions. It should not matter if “A”, “B” or “C” walk into a shop to make their purchase or if they call in an order from their business location, or even if they place their order over the Internet. Nor should it matter when completing the sale if the

¹⁰ Assume 1.0 carat colorless princess diamonds of certified flawless clarity and excellent proportions which sell for (US) \$16,750.00 on August 10, 2016. 25 diamonds of this quality would be worth (US) \$ 418,750, or (SR) 1,570,442. For purposes of this example the price is rounded to (SR) 1.5 million.

¹¹ Sarah Diao, *UAE outlines VAT threshold for firms in Phase I*, GULF NEWS (August 15, 2015) (indicating that the UAE Undersecretary of the Ministry of Finance, Younis Al Khoury provided comments on the VAT filing requirements to Mubasher, the financial markets website and data provider, and which were later confirmed by the Gulf News that businesses with turnover in excess of 3.75 million (AED) [3,829,233 (SAR)] would be required to file under the first phase of the VAT) *available at*: <http://m.gulfnews.com/business/economy/uae-outlines-vat-threshold-for-firms-in-phase-1-1.1847025>

goods are transported by or for the seller or by or for the buyer. The VAT should be the same in all instances.

“A’s” PURCHASE – THE “FAIRNESS” STANDARD

Common example applied to “A”. Regardless of the approach taken by the GCC’s agreed framework “A” will not be impacted by the rules for intra-Gulf trade. “A” is engaged in a purely domestic transaction. The following results happen for “A”:

- “A” will pay (SAR) 1.5 million for the 25 diamonds to the store-owner;
- “A” will pay (SAR) 75,000 in Saudi VAT to the store-owner;¹²
- “A” will deduct the VAT paid (as an input) on its next Saudi VAT return; and
- the store-owner will include the same amount on its next Saudi VAT return (as an output).

“A” will suffer the loss of the time-value-of-money for the VAT he paid for the period between the payment and his deduction of this amount on his next Saudi return.¹³ If “A” placed his order from his business location in Riyadh, instead of personally going into the shop there would be no tax difference. Delivery methods would not matter.

CUSTOMS IMPLEMENTATION

Common example applied to “B”. The intra-Gulf rules for the sale of goods will directly impact “B’s” transaction. Parts of “B” transaction will be just like “A”. “B” will:

- pay (SAR) 1.5 million for the 25 diamonds to the store-owner;
- pay (SAR) 75,000 in Saudi VAT to the store-owner, and
- receive an invoice recording this transaction.

However, “B” does not file a Saudi VAT return. “B” is the owner of a UAE business. “B” proceeds to the Saudi/ UAE border with diamonds and invoice in hand. This is the point in “B’s” transaction where customs gets involved:

- the invoice “B” has received recording his purchase and the Saudi VAT receipt is presented to the Saudi customs official at the Saudi/ UAE border, and
 - the diamonds are inspected,
 - a new receipt is issued, and
 - a refund of the Saudi VAT is delivered to “B”.

Moving ahead to the UAE side of the common border, a second set of customs officials step forward and complete the inspection and the transfer of the VAT payment. “B” will:

¹² Roughly (US) \$46,660.

¹³ Because “A” is a business selling diamond rings which will also be subject to VAT at 5% it is possible that “A” will collect a significant amount of output VAT before his return is due. In this case (depending on the amount of VAT collected) “A” could be in a net positive position, holding more VAT due to the government than it has accrued as deductions.

- present the diamonds for inspection (again) along with the paper trail of the transaction;
- receive an assessment for 5% UAE VAT
- pay the equivalent of (SAR) 75,000 in UAE VAT or (AED) 73,452 to the customs agents.¹⁴

Effectively, the Saudi/ UAE customs procedure has retro-actively “zero-rated” the Saudi transaction that took place at the diamond merchant’s shop in Riyadh. Even though the diamond merchant charged VAT, and is prepared to remit this VAT with its Saudi return, the Saudi customs officials have given this tax back to “B” when he crosses the border out of the country. “B’s” Saudi VAT payment has been effectively converted into a UAE VAT payment by the UAE customs agents.

At this point, “A” and “B” are in the same economic position. Both have paid (SAR) 75,000 in VAT and both have lost the economic use of that money until they are able to file returns and take deductions for the input VAT paid.¹⁵ The only real difference is that “A’s” return will be a Saudi return and the Saudi Treasury will hold his VAT, and “B’s” return will be a UAE return and the UAE Treasury will hold his VAT.

If “B” ordered the diamonds remotely from his business location in the UAE, then there would be no significant change in the process above. The merchant-seller would still impose Saudi VAT on the transaction. “B” will pay the full amount due (although probably not in cash).

As the diamonds cross the Saudi/ UAE border customs officials will perform the same inspections, refund Saudi VAT, assess and collect UAE VAT. Third-party shipping agents will engage the customs officials on behalf of either the seller (if the contract of sale included delivery by the seller) or on behalf of the buyer (if the contract of sale required the buyer to secure shipping). There would be no material tax-difference. The end result would be that when the diamonds arrive at “B’s” business location, UAE VAT would be paid and would be available as an input deduction on the UAE VAT return.

Common example applied to “C”. “C’s” situation would be similar to “B’s”, except “C” will pass through Saudi customs at the airport where he will receive a full refund of the (SAR) 75,000 VAT. In the UK “C” will be subject to VAT on the importation of diamonds at 20%¹⁶

¹⁴ The role of the customs agents in this transaction is important. Without customs agents backing up the transaction, and facilitating the transfer of VAT from Saudi to UAE tax authorities, “B” would want to be exempt from Saudi VAT. “B” would want to pay UAE VAT so that “B” could get an input VAT credit on its UAE VAT return. Requiring “B” to pay Saudi VAT and then seek a Saudi refund would not only be cumbersome, it would be expensive. The UAE VAT would also need to be paid.

¹⁵ This assumes that only one transaction is made. Sale of any of the diamond rings would be subject to VAT which “A” or “B” would hold until their return is filed. It is possible that these traders are in a net positive position.

¹⁶ If “C” wanted to avoid the UK VAT, there are a number of other jurisdictions where diamond imports are exempt. French Guiana, Guernsey, Hong Kong, Lebanon, Macau, Mayotte, Saint Martin, San Marino, Sri Lanka, Turkey, and the United States are among the jurisdictions where no duties or taxes are imposed

“C” is treated differently than “A” or “B”, but not because of the Arabian VAT. The difference in treatment is entirely due to the UK. “C” is not being treated any differently than “A” or “B” *within the GCC*.

“C” could order the diamonds remotely (from the UK), and have them shipped by a third-party carrier. Saudi customs documents would be prepared before shipping by the seller.¹⁷ Saudi customs would inspect the shipment to verify that the diamonds that were sold (per the invoice) without VAT were in fact being transferred out of the country. UK customs would be notified that loose diamonds were being shipped.

Analysis. A pure customs-based implementation essentially uses customs agents to convert an origin-based VAT into a destination VAT. VAT is always collected (initially) at the point of sale and then it is converted to a destination VAT at the border. In the common example, customs agents (acting together) effectively zero-rate the Saudi transaction, and replace it with a UAE transaction.

Should the GCC ask customs agents at the intra-Gulf borders to oversee cross-border VAT compliance in goods? Should they confirm that VAT payments were made (in the seller’s jurisdiction), and collect destination VAT (for the buyer’s jurisdiction)? Would this activity negatively impact intra-Gulf trade? Does it open up avenues for VAT fraud in the Gulf? Is there a way that technology could streamline this process?

Commercial aspects of VAT inspections by customs. The customs inspection option was utilized for intra-community VAT compliance in the EU until January 1, 1993. Up until this date customs agents from two adjoining Member States performed the above-described VAT compliance functions at the internal EU borders. Each intra-EU shipment encountered two sets of customs agents. This delayed the free flow of trade at the border, and hampered the development of the Single Market.

Trade issues (not VAT fraud) compelled a change in this practice. On January 1, 1993 VAT inspections as well as many conflicting regulatory structures were removed from intra-community trade. An indication of how difficult this change was to make is reflected in the extended time line and the number of studies and commentary that went into making it. A 1985 White Paper¹⁸ began the intra-community trade debate in earnest, and was immediately followed with a seven-year commercial impact study. In 1991 a

on the importation of loose diamonds. Pitney Bowes, *Global Trading Solutions – Import Duty & Taxes for Loose Diamonds*, available at: <http://www.dutycalculator.com/dc/257684/bags-shoes-watches-accessories/watches-jewellery/diamonds-not-mounted-or-set/import-duty-rate-for-importing-loose-diamonds-from-belgium-to-united-kingdom-is-0/>

¹⁷ VAT would most likely not be collected if there were a “duty free/ tax free” provision in the Saudi VAT law, and the Saudi Diamond Dealer set up a qualifying duty free department.

¹⁸ White Paper COM(85) 310 final, 52 (June 14, 1985) available at: http://europa.eu/documents/comm/white_papers/pdf/com1985_0310_f_en.pdf (there were significant non-tax reasons for removing internal borders; reasons largely relating to trucking regulations and divergent national product standards).

decision was made to change the then-current practices within two years (1993).¹⁹ This was a difficult eight-year decision process.

The lesson to be learned is that once VAT compliance gets rooted in customs procedures at the internal borders of an economic community, it gets very difficult to remove. If this is the direction that the GCC Framework will take to assure intra-Gulf VAT compliance, then EU history suggests that this mechanism is likely to stay in place for a considerable period of time. If the customs impact on trade in the GCC echoes that in the EU, then this decision may negatively impact economic development.

The commercial impact study commissioned by the EU quantified the *benefits* to the then twelve EU Member States of removing internal customs/ VAT borders.²⁰ The study showed that customs activity held back trade, and hampered small business expansion and innovation. It concluded:

- Customs related costs (including VAT compliance) was a charge on companies roughly equal to 25% of the profits generated from intra-community trade, and
- Smaller companies were effectively barred from cross-border trade by administrative costs and regulatory complexity.

The commercial wisdom of the 1993 decision was re-affirmed recently. A 2016 retrospective study considered the commercial impact of *re-establishing* the traditional customs-compliance borders in the EU (that is, what would happen if the EU went back to the pre-1993 rules). Customs borders were hypothetically re-established, and economic models were run. The result was that the EU GDP would fall by around €37.5 billion.²¹

Thus, the EU experience argues against placing tax compliance functions at the internal borders of an economic community. Normal wait-time for commercial trucking at the Saudi border is 24 to 36 hours. In some instances, the wait can approach six days. 18km queue of trucks have been reported.²² Similar delays can be found at the Bahrain/Saudi border where 10 km queues have been reported.²³ For purely commercial reasons, adding cross-border VAT compliance to the duties of customs agents would be bad for business.

¹⁹ 1991 O.J. (L 376) 1;

²⁰ The reality was that intra-EU trade in goods soared from €800 billion in 1992 to €2,800 billion in 2011. This increase was from 12% of EU GDP to 22% in 2011. European Commission, *20 Years of the European Single Market – Together for new growth – Main Achievements (1992-2012)* available at: http://ec.europa.eu/internal_market/publications/docs/20years/achievements-web_en.pdf

²¹ Gabriel Felbermayr, Jasmin Gröschl & Thomas Steinwachs, *Trade Costs of Border Controls in the Schengen Area*, VOX CEPR'S POLICY PORTAL (April 27, 2016) available at: <http://voxeu.org/article/trade-costs-border-controls-schengen-area>

²² Mick O'Reilly & Jumana Al Tamimi, *Trucks queue at Saudi border stretched to 18 km*, Gulf News (April 2, 2012) available at: <http://gulfnews.com/news/uae/transport/truck-queue-at-saudi-border-stretches-to-18km-1.1002810>

²³ Andy Sambridge, *10km truck queues at Bahrain-Saudi border*, ARABIAN BUSINESS.COM (June 22, 2009) available at: <http://www.arabianbusiness.com/10km-truck-queues-at-bahrain-saudi-border-16890.html#.V6f4NpMrKbU>

Fraud opportunities inherent in a customs regime. A related problem is that missing trader fraud can be facilitated by a pure customs implementation, especially when the customs agents are under considerable pressure to speed up the clearance of backlogged goods.

This type of missing trader fraud takes advantage of timing gaps between (immediate) VAT refunds at the border, and (delayed) VAT payments at the point of sale. It can be compounded with the presentation of fake goods to the customs agents at the border, and poor communication among VAT jurisdiction. The following figure illustrates.

Figure 1: Missing Trader – pure customs implementation

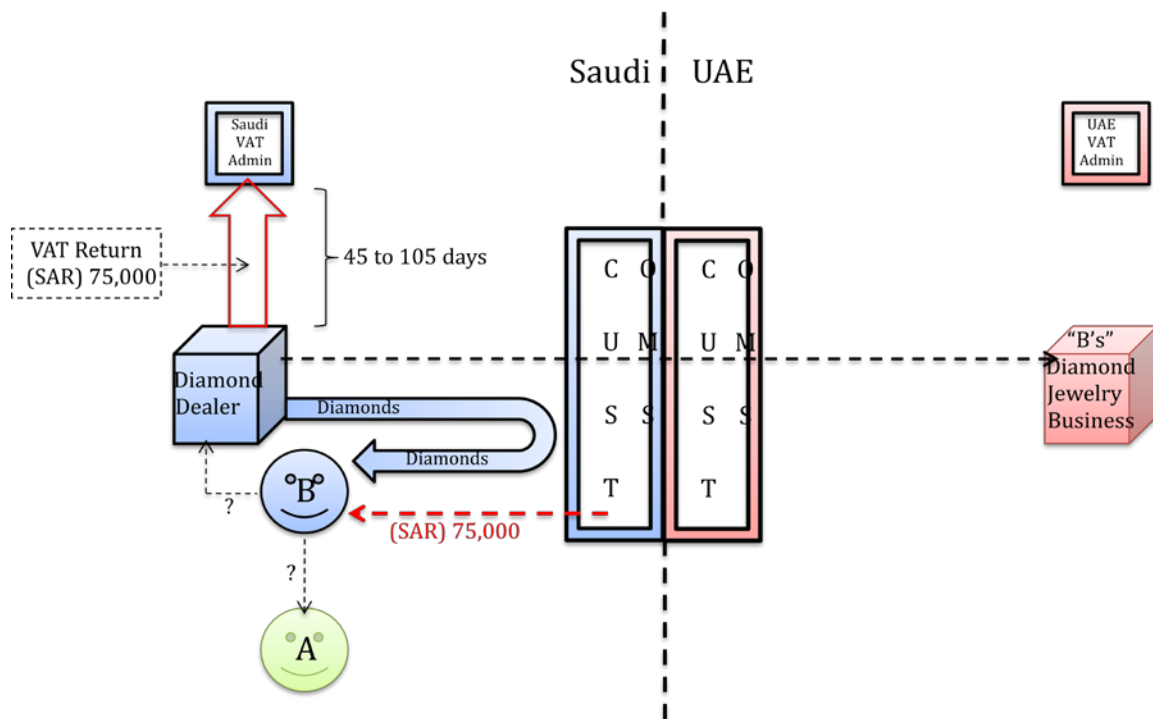

If “B” purchased diamonds on the first day of the month from the Saudi merchant, VAT of (SAR) 75,000 would be paid immediately. If “B” proceeded to the border to return to the UAE the same day a fraudster could present fake diamonds for customs inspection (relying either on corruption or overworked staff to get his shipment approved) and secure a refund *before* the tax of (SAR) 75,000 was deposited in the bank, and certainly before a return was filed and the VAT paid into the Saudi Treasury.²⁴

²⁴ Megan Willett, *5 Ways to Spot a Fake Diamond*, BUSINESS INSIDER (January 16, 2015) (indicating that it is possible to get a rough idea if a diamond is fake by viewing the stone through a jeweler’s loupe, but that fake stones are reasonably common and could be white sapphire, white topaz, cubic zirconium, moissanite

“B” would now have, *within Saudi Arabia*, a supply of VAT-free diamonds he could sell *with VAT*. His sale could even be for less than the market price. If the original diamond dealer participated in the fraud then he could re-purchase the diamonds. In this case, the real diamonds would go around in a carousel. It is also possible that “B” could sell to “A,” and also charge VAT.

Given the current work-load of Saudi customs it is unlikely that substantive verification of the transactional data and the diamonds would occur. Sorting fake from real diamonds is an art that may not be in ready supply at the Saudi/ UAE border.

In terms of data verification, this system is asking the customs agents to perform a remote audit without all the data. Things they would not know include: (1) whether the VAT was actually paid – the cash bank deposit of (SAR) 75,000 by the diamond merchant probably will not have occurred, although a paper receipt and invoice would be available, (2) whether the Saudi VAT return will be filed – this will occur within the span of 45 to 105 days, (3) whether the Saudi Treasury will actually receive the tax payment – payments are normally made with the filing of the return, and (4) whether “B” is a valid business in the UAE qualifying for the zero-rate, a process that would require a substantive check of the business .

Serious fraud will arise when traders draft false invoices, show up at the border with a supply of fake diamonds, and then disappear after collecting a VAT refund. Fraudsters can secure refunds of VAT that was *never* paid. Tracing would be nearly impossible. The transactions would not be referenced on any returns.

Conclusion. A pure customs-at-the-border VAT compliance regime would delay commercial transactions, and create opportunities for missing trader frauds as customs agents try to speed the flow of commerce. Frauds would be very difficult to detect.

The inability of customs to immediately check transaction data in real-time will create a pathway for refund fraud, bringing VAT-free products into the domestic market. This will eventually destabilize the internal market for diamonds, and the fraudulent VAT refunds would be long gone by the time the authorities look for them.

ACCOUNTING IMPLEMENTATION

When the EU abolished internal borders in 1993, VAT compliance on B2B cross-border transactions in goods became a purely accounting matter.²⁵ The new accounts-based system was to be temporary, but it has remained for nearly 25 years. Under this system intra-community supplies are zero-rated (by the supplier) and intra-community

or a lab grown diamond) available at: <http://www.businessinsider.com/how-to-tell-if-a-diamond-is-fake-or-real-2015-1>

²⁵ Ernst Verwaal & Sijbren Cnossen, *Europe's New Border Taxes*, CESIFO WORKING PAPER No. 434 (March 2001) (discussing the new rules and calculating the compliance cost at 5% of the value of intra-EU trade).

acquisitions are self-assessed (by the buyer), or in EU terminology, they are subject to a *reverse charge*.

There were two strong arguments favoring the 1993 system. It should work (it was argued) because: (1) it mimicked the customs regime, and (2) it was already in use with cross-border services. The 1993 change simply amounted to replacing physical (customs) enforcement with professional (accounting) enforcement.

We now know that the EU's *reverse charge* does not work. It is highly vulnerable to fraud. MTIC fraud in goods, and MTEC fraud in services takes in excess of €100 billion from EU treasuries each year. As a result, the EU is planning to re-cast its *reverse charge* accounting approach. The new system is sketched (without details) in the *Action Plan on VAT – Towards a Single EU VAT Area*.²⁶ It is another accounting approach – using a *one-stop-shop*.

It has not been disclosed if the GCC Framework agreement will adopt either of the EU accounts-based regimes for intra-Gulf transactions – the *reverse charge* or the *one-stop-shop* approach. However, if we consider both approaches carefully, it seems *unlikely* that the traditional EU *reverse charge* will be employed in either cross-border goods or services transactions.

This assessment is clearer if we consider “B’s” position in the common example first in terms of the *reverse charge* approach, and then in terms of the *one-stop-shop*.

Reverse Charge Approach

In the common example, “B,” a UAE business, purchases diamonds from a merchant in Saudi Arabia for use in “B’s” jewelry-making business activity. This is an intra-Gulf B2B transaction. In a destination VAT the tax imposed on this transaction should be UAE VAT, not Saudi VAT.

Under *reverse charge* treatment, when “B” convinces the diamond merchant that the sale is B2B, and that he is a UAE business,²⁷ the merchant will draft an invoice with a Saudi VAT of 0%. Under EU rules the merchant would need to believe (with objective evidence) that the diamonds were going to physically leave the jurisdiction.²⁸ The invoice will demand payment of (SAR) 1.5 million for 25, 1-carat princess diamonds and include no Saudi VAT.

On his next UAE return B is obligated to self-assess the 5% UAE VAT by hypothetically selling the diamonds to himself. The VAT due is (AED) 73,452. This is

²⁶ EU Commission, *Action Plan on VAT* (April 7, 2016) available at:

http://ec.europa.eu/taxation_customs/taxation/vat/action_plan/index_en.htm

²⁷ Although the most common way of doing this would be to present the diamond merchant with a valid VAT ID from the UAE, in the EU the ECJ has deemed the VAT ID to be helpful, but not a necessary requirement. *Vogtländische Straßen-, Tief- und Rohrleitungsbau GmbH Rodewisch (VSTR) v. Finanzamt Plauen*, Case C-587/10 (September 27, 2012).

²⁸ *Teleos, plc & Others v. Commissioners of Customs & Excise*, Case C-409/04 (September 27, 2007).

precisely the same outcome obtained under the customs regime, but it is accomplished through accounting.

The system is called “deferred payment” because VAT does not have to be paid upfront (at the shop or with the customs agent at the border).²⁹ It is paid later, when the return is filed. As a result, “B” does not suffer the time-value-of money loss associated with paying VAT close to the point of sale.

This treatment prefers “B” over “A,” because “A” has lost the time-value-of-money for his entire VAT payment. “B” has the benefit of holding his VAT payment until his return is filed. Generally, a *reverse charge* system preferences buyers over sellers.

This is the opposite of a *customs-based* system which preferences the shop-owner seller of diamonds (who collected Saudi VAT upfront in the common example) over intra-Gulf buyers who cannot secure a refund until they file VAT return (the UAE return in the common example).

There are more fundamental problems with a “deferred payment” system. The EU has no audit mechanism to pair and confirm both parts of a reverse charge procedure in anything close to real time. Enforcement is entirely retrospective, and frequently occurs (if at all) many months after a transaction is closed. There is a strong incentive for “B” to go missing, to not report the purchase, and to sell his diamonds onward collecting VAT and not reporting it.

²⁹ Deferred payment had proven to be workable in the Benelux area (Belgium, Luxembourg and the Netherlands), which introduced a coordinated system of VATs in the late 1960’s and early 1970’s. Prior to 1993 a similar practice arose between Ireland and the UK where it was called “postponed accounting.” Sijbren Cnossen *Value-Added Tax and Excises: Commentary (Prepared for the Report of a Commission on Reforming the Tax System for the 21st Century Chaired by Sir James Mirrlees* THE INSTITUTE FOR FISCAL STUDIES (February 19, 2008).

Figure 2: Missing Trader – reverse charge implementation

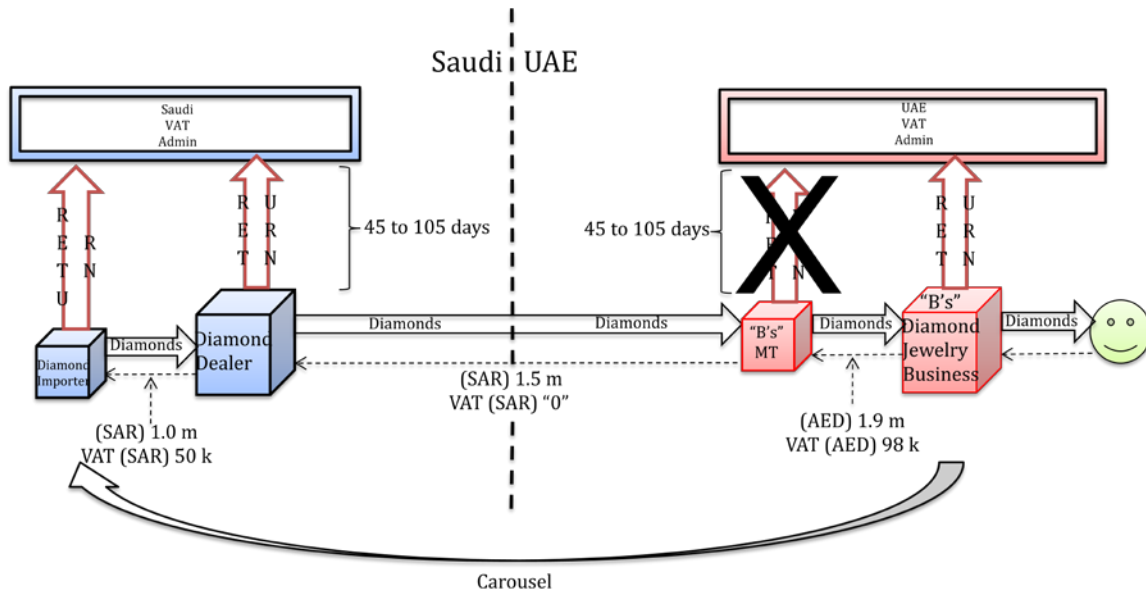

This figure expands the common example on both ends to more clearly demonstrate the problem with deferred payment systems. Assume the Saudi diamond dealer acquired the 25, 1-carat princess diamonds for (SAR) 1.0 million from a bulk Saudi diamond importer/ distributor. The diamond dealer pays a (SAR) 50,000 input VAT. These diamonds are then sold to “B” for (SAR) 1.5 million.

Assume further that “B” does not purchase in his own name or the name of his jewelry business. Instead “B” (or an associate) sets up a shell company in the UAE to make the purchases. The shell will be a missing trader (MT). The MT has a VAT ID, but no employees or business location other than a mailbox where packages can be dropped off. “B” purchases the 25, 1-carat princess diamonds through MT. The MT then re-sells the diamonds to “B’s Diamond Jewelry Business” for the equivalent of (SAR) 2.0 million [(AED) 1,958,943] with VAT of (SAR) 100,000 [(AED) 97,947].

At this point “B” could either (a) put the diamond in a ring and sell to consumers in the UAE, or (b) re-export the loose diamonds back to the Saudi importer. If (b) is selected, then we would have the beginnings of a carousel fraud whereby the same diamond will travel in a circle picking up (AED) 98,000 each turn.³⁰ It is exceptionally

³⁰ Each sale of diamonds from “B’s” MT to “B’s” Diamond Jewelry Business leaves in the “B’s” MT accounts (AED) 98,000 in VAT and (AED) 489,683 in profits (which is the difference between what “B’s” MT paid for the diamonds (AED 1,469,2600) and what it is able to sell them for to “B’s” Diamond Jewelry Business (AED 1,958,943). The total “profit” is (AED) 587,683. It can be repeated in a carousel.

easy for professional fraudsters to work a fraud that will take millions from the treasury in the space between the filing of two VAT returns.³¹

The problem is that the fraud occurs in one day, but none of the evidence of the fraud shows up at the UAE or Saudi tax administration until 45 or 105 days have passed. There is no real-time record of these transactions, nothing for either tax administration to notice as suspicious.

A reverse charge is even more damaging when the supply is a cross-border tradable service, for example VoIP rights, or CO2 permits, and when the supply can be transferred digitally. The same pattern in the diagram (above) can be used, if we replace Saudi Arabia with the UK, and replace diamonds with VoIP rights.

In this case, unlike diamonds, which last forever, VoIP rights evaporate upon use. Real-time transactional data is critical to any audit oversight in this market segment. These are MTEC frauds.³² They are not limited to economic communities as are good-based MTIC frauds.

One-Stop-Shop Approach

The other account-based approach to effectively monitoring intra-community cross-border VAT compliance is to use a *one-stop-shop*. This system can be illustrated with the common example in the following manner.

Once again, “B,” a UAE business-owner, purchases diamonds from a merchant in Saudi Arabia for use in “B’s” jewelry-making business activity. We also know that the Saudi Diamond Dealer has acquired the diamonds in bulk from a Saudi Diamond Importer. The primary transaction is a B2B intra-Gulf transaction.

Because the GCC Framework requires a destination VAT the Saudi diamond dealer *should* collect UAE VAT from “B” (the destination jurisdiction VAT). It *should not be* Saudi VAT. When we complete the commercial chain we see that “B” sells the diamonds on. He places them in fine jewelry settings, and provides them to UAE consumers. The *one-stop-shop* is only concerned with the cross-border part of this commercial chain.

A *one-stop-shop* requires that the Saudi Diamond Dealer collect UAE VAT on his sale. However, under a *one-stop-shop* regime, the Saudi diamond merchant:

- will not be considered a UAE business,
- will not be considered a UAE taxpayer,

³¹ See for example, Sandeep Dosanjh whose fraud stole £39m (€41,039,261) from the UK Exchequer in 69 days (January 20, 2009 through May 6, 2009) *R v. Dosanjh (Sandeep) and others* [2013] EWCA Crim 2366 (November 20, 2013). Richard T. Ainsworth, *VAT Fraud Mutation, Part I: “Push” Missing Trade Fraud and Dosanjh*, 81 TAX NOTES INTERNATIONAL 535 (February 8, 2016).

³² In a follow-up paper we will examine the implications of a VAT in the GCC on trade in services which are highly prone to MTEC frauds involving third-country suppliers. Special VAT rules are needed in this sector.

- will not be required to file a UAE return, and
- will not be required to remit to the UAE VAT he has collected the UAE.

All of the Saudi diamond merchant's VAT compliance will be directly with Saudi Arabia, with one possible exception – an audit of this transaction might be the responsibility of the UAE tax administration as well as the Saudi tax administration. The Saudi government will transmit all necessary documents and the VAT to the UAE on behalf of the diamond merchant (see figure 3 below).

Figure 3: One-Stop-Shop – accounts-based implementation

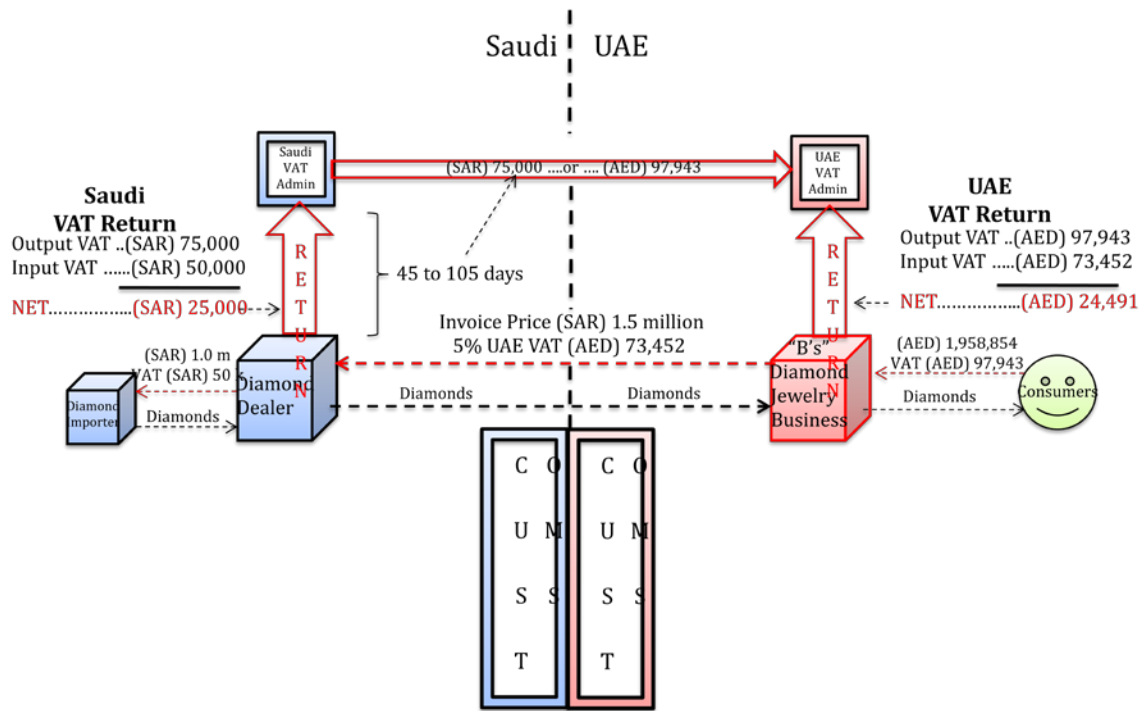

The *one-stop-shop* concept is not new. Its genesis was in the US where it has long been used in the retail sales tax (RST) in States where there are a large number of sub-State jurisdictions (counties, cities, as well as various water, fire and transportations districts) imposing add-on sales taxes. There are over 13,000 RSTs in the 45 US States that impose RSTs. This same *one-stop-shop* concept has been under gradual adopted in the EU where it initially was used to solve problems with e-commerce distant sales. Its application has been under continual expansion in the EU. There is something for the GCC to learn from both the EU and the US experiences.³³

EU's One-Stop-Shops

³³ For a more detailed consideration of the US and EU *one-stop-shops* see: Richard T. Ainsworth, *The One-Stop-Shop in VAT and RST: Common Approaches to EU-US Consumption Tax Problems*, 37 TAX NOTES INTERNATIONAL 693 (February 21, 2005).

The EU began exploring one-stop-shops in the late 1990's with a limited proposal in 2000 that dealt with non-EU established persons supplying digital products to non-taxable EU persons.³⁴ In March 2004 the EU Commission issued a *Consultation Paper* proposing that businesses established within the EU be allowed to participate in a similar one-stop-shop scheme. Again limited to B2C transactions this new scheme encompassed more than digital sales. After a five-month public comment period the Commission proposed two Council Directives and a Council Regulation³⁵ that far exceeded the vision of March *Consultation Paper*.³⁶

There have been five distinct phases in the EU's one-stop-shop initiative: (1) the digital sales directive,³⁷ (2) the limited one-stop-shop proposal in the March 2004 *Consultation Paper*, (3) the expansive one-stop-shop proposals of October 29, 2004, (4) the Commission's pull back from full implementation of a European one-stop scheme due in part to burdens "... dealing with the re-distribution of money received [which would require] ... [d]eveloping the kind of major treasury function needed to handle the volume of money flows which would be inherent to a much wider application..."³⁸ and (5) the new one-stop-shop proposal set out in the 2016 *Action Plan on VAT – Towards a Single EU VAT Area*.³⁹

Item (4) should be of considerable interest to the GCC. Why did the EU *pull back* from full implementation of the *one-stop-shop*? Can the GCC solve the "... re-distribution of money ..." issues that hampered EU progress? This paper argues that one of the most striking aspects of the GCC framework agreement is that it has convincingly solved this problem. Other economic communities, notably the East African Community (EAC) and the EU itself, should take notice. The solution is a harmonized rate.

US's One-Stop-Shops

In the US version of the *one-stop-shop* procedure all RST revenue collected from sub-State jurisdictions where a business is engaged is sent centrally (one return and one deposit). The State then re-distributes return-data and funds to each sub-jurisdiction

³⁴ This scheme essentially applies only in B2C transactions where the B is a business located outside the EU (non-established in the EU) and the C is an individual purchasing electronic services for personal consumption within the EU. Although primarily directed at individuals, C in this instance could also be an exempt legal entity (non-taxable person), like a government department, university or hospital.

³⁵ *VAT Directive*, Articles 369a-369k and *Regulation (EU) No. 282/2011*.

³⁶ COM(2004) 728 final. Available at:

http://europa.eu.int/comm/taxation_customs/publications/official_doc/COM_728_en.pdf

³⁷ The digital sales scheme is found in Articles 358-369 of the *VAT Directive*. This was formerly Article 26c of the *Sixth VAT Directive*, 77/388/EEC of May 17, 1977 on the harmonization of the laws of the Member States of the European Union relating to turnover taxes – Common system of Value Added Tax: Uniform Basis of Assessment (OJ L 145, 13.6.1977). The *Sixth VAT Directive* was repealed and replaced on November 28, 2006 with the *Recast VAT Directive*, Council Directive 2006/112/EC on the Common system of value added tax, O.J. (L 347) 1. [Hereinafter *VAT Directive*]

³⁸ COM(2004) 728 final, page 5. Available at:

http://europa.eu.int/comm/taxation_customs/publications/official_doc/COM_728_en.pdf

³⁹ EU Commission, *Action Plan on VAT* (April 7, 2016) available at:

http://ec.europa.eu/taxation_customs/taxation/vat/action_plan/index_en.htm

according to the reported tax incidence. Audits, adjustments and refunds are all controlled centrally.

In 34 of the 45 US States that impose a state level RST, the local jurisdictions impose RSTs of their own.⁴⁰ Variances are common between states, among local jurisdictions within the same state, as well as between the State and local governments. Local and aggregate rates commonly vary across a single State, as do the tax bases. Differences are the result of political decisions about the acceptable scope of taxation.

In 25 of these 34 states⁴¹ a *one-stop-shop* operates to collect the RST for *all* local jurisdictions. These *one-stop-shops* redistribute taxes collected from the taxpayer to each locality according to where consumption occurred (in the instance of destination-based RSTs) or where the sale occurred (in the instance of origin-based RSTs). This redistribution is accomplished in all instances with unitary taxpayer identification numbers and reporting requirements. Some *one-stop-shops* allow filing only with traditional paper forms. Others allow the taxpayer to elect to file either on paper or in an electronic format. Still others make electronic filing mandatory.

In 5 states⁴² there is a combined system where a *one-stop-shop* is in use for some sub-State jurisdictions, while other sub-State jurisdictions have an autonomous local reporting and collection process.

As opposed to the EU model, US *one-stop-shops* facilitate diversity rather than homogenize it. Tax rates and tax bases do *not* have to be the same for the US *one-stop-shop* to work. This is not the case in the EU where the workability of the *one-stop-shop* is in question because of rate differentials. These differences are in large part a direct result of the difference between the RST and the VAT. *One-stop-VAT-shops* that cross borders need to deal with revenues collected (output VAT), as well as deductions allowed (input VAT). *One-stop-RST-shops* are less complicated. They are concerned only with funds collected.

⁴⁰ In the 9 other states (Connecticut, Hawaii, Indiana, Kentucky, Maine, Maryland, Massachusetts, Michigan, Mississippi, New Jersey, Rhode Island, and West Virginia, as well as the District of Columbia) there is only a state level RST, and no need for a one-stop-shop. There are some limited exceptions to this rule. In these cases no one-stop-shop functions to facilitate compliance. Some counties in Indiana are authorized to levy miscellaneous local taxes on specified transactions. *Illinois Code* 6-9-34-1. In Mississippi even though general sale taxes at the local level are not permitted, some counties and cities are permitted to impose hotel-motel occupancy and taxes on restaurant sales. *Miss. Code Ann.* § 27-65-73. In New Jersey only Atlantic City imposes a local levy on specific types of retail sales. *New Jersey Statutes Annotated*, Section 40:48-8.15. In Rhode Island an additional 1% levy is added to meals and beverage sales for local use. *General Laws of Rhode Island*, Section 44-18-19.1. Effective on July 1, 2005 a general sales and use tax may be imposed by municipalities in West Virginia. *West Virginia Code*, Section 8-13C-6.

⁴¹ The 25 states are: Arkansas, California, Florida, Georgia, Illinois, Iowa, Kansas, Missouri, Nebraska, Nevada, New Mexico, New York, North Carolina, North Dakota, Ohio, Oklahoma, Pennsylvania, South Carolina, South Dakota, Tennessee, Texas, Utah, Virginia, Washington, and Wyoming.

⁴² The 5 states are: Alabama, Arizona, Colorado, Minnesota, and Wisconsin.

Analysis. As set out in figure 3 above, the hypothetical GCC *one-stop-shop* avoids customs controls. Assuming there is just the one transaction (using the common example), it is possible to set out the Diamond Merchant's Saudi VAT return. He paid (SAR) 1.0 million to acquire diamonds with a VAT of 5% or (SAR) 50,000. He sells to "B" at (SAR) 1.5 million with VAT in addition of (AED) 73,452.

Because of the different currencies involved it is not clear if this VAT payment will be made in Saudi Arabian Riyal (SAR) or Emirati Dirham (AED). Figure 3 assume Emirati Dirham will be chosen.

The UAE return can also be set out. Assuming "B's" Diamond Jewelry Business sells the diamonds to the public for (AED) 1,958,854 and receives VAT of (AED) 97,943 on these sales, then the VAT return will show an amount due of (AED) 24,491. Importantly, "B" is allowed a UAE deduction for the VAT he paid to the Saudi Diamond Dealer.

When the Saudi return is filed, and it is confirmed that an intra-Gulf transaction with the UAE is involved, then the Saudi VAT Administration will send to the UAE VAT Administration copies of all documentation related to the sale as well as the full amount of VAT collected from the entire Saudi chain (up to and including this final sale). That amount is (AED) 97,943.

Although the *one-stop-shop* gets a lot of things right, there are serious difficulties with it, which the GCC will need to address if it plans to use this device. The most notable are:

- the absence of a *real-time data exchange* from taxpayer to tax authorities, and between the tax authorities – there remains a 45 to 105 day gap between the commercial transactions and the arrival of return data at the tax authority, with inter-governmental sharing taking some time longer (up to 3 months in comparable EU tax-data sharing contexts);
- the potential for serious workability issues throughout the system if *tax rates, or tax bases differ* among the Member States; and
- the loss of "*audit*" *sovereignty*, reflected in the necessity for tax authorities to wait for another tax authority to process and hand off tax-data and the related tax amounts that have accumulated in the supply chain in the other Member State.

The GCC seems to have solved the second point above. The problem here is that differential rates destabilize the commercial marketplace. If (for example) the Saudi rate was 10%, and the UAE rate remained at 5%, then too much VAT would be collected on value added in Saudi Arabia. All the accumulated VAT would pass to the UAE through the *one-stop-shop*, but this would overprice the diamonds in the UAE. The UAE final consumer would bear the burden of this excessive tax. The same would happen in reverse, if the Saudi rate was 5% and the UAE rate was 10%. These diamonds would be under-priced in the UAE market, and consumers would favor them. Similar issues arise when the tax base differs among Member States.

The differential rates problem is a significant barrier to the adoption of the *one-stop-shop* in the EU, but the GCC the Framework agreement has set the rates in each of the Member States uniformly. It is understood that for any VAT rate to rise above or fall below 5%, all six countries will have to move in tandem.

TECHNOLOGICAL (REAL-TIME) IMPLEMENTATION

The technological implementation option that achieves real-time cross-border data sharing is DICE, the Digital Invoice Customs Exchange. The Achilles heel of cross-border VAT compliance in a community has always been – how to achieve granular (transaction-level) data-sharing in real-time.

Only a few communities have accomplished real-time data-sharing. The clear leader is Brazil, an economic community of 28 states. Eleven of the American *one-stop-shops* achieved a level of digital compliance in the RST that permits intra-jurisdictional data-sharing. However the American data is not granular, and is not shared in real-time.⁴³ In the East African Community there is a single-state implementation of DICE (Rwanda), but the other Member States have yet to match this commitment (although it is expected).⁴⁴ DICE is proposed as a modernization of the EU's VAT Information Exchange System (VIES) within the framework of a Third Invoicing Directive.⁴⁵

DICE applies the lessons learned in the Brazilian *Sistema Publico de Escrituracao Digital* or Public System for Digital Accounting (SPED). It works in conjunction with one or more of the other cross-border enforcement structures considered in this study:

- a *customs* approach,
- a *reverse charge* approach; or
- a *one-stop-shop* approach.

DICE improves the efficiency and the performance of these systems. It cures some of their inherent ills.

DICE

DICE requires a modification of commercial law. Brazil, for example, requires an invoice to be digital to be enforceable. Paper invoices are acceptable only as replicas or evidence of the prior digital invoice.

⁴³ Alabama, Connecticut, Florida, Louisiana, Minnesota, Missouri, New Jersey, New York, Oklahoma, Texas, and Utah are discussed. Each state mandates digital returns that present aggregate data for transactions within a sub-jurisdiction, and require digital transfers of funds, but this is not enough detail for the sub-jurisdiction to conduct an audit. See: Ainsworth, *One-Stop-Shop* 37 TNI 693 (Feb. 21, 2005) at *supra* note 33, n. 31,

⁴⁴ The East African Community is comprised of Kenya, Uganda, Tanzania, Burundi and Rwanda.

⁴⁵ Richard T. Ainsworth, *Stopping EU VAT Fraud with a Third Invoicing Directive*, 72 Tax Notes International 545 (August 5, 2013)

There are two digital invoice models in Latin America: the Chilean model that allows companies to voluntarily adopt digital invoices;⁴⁶ the Brazilian model that mandates digital invoices for companies of a certain size.⁴⁷ In Brazil this threshold has been progressively lowered to bring more businesses into the digital invoice system. Once a firm has begun to use digital invoices it cannot revert to paper. The Brazilian model is preferred for DICE.

The six steps in the development of a *digital invoice* system are set out briefly below, and in Figure 4. An operational system can be seen in Brazil, Chile, Rwanda, and is under consideration in Nigeria and Mozambique. Data Tech International installed the Rwandan system, and is working on similar installs in other jurisdictions.

STEP 1: The seller generates an electronic file that contains all necessary contract and tax information for the sale of goods or services (a pro-forma digital invoice). The issuer digitally signs the file (to assure integrity of the data and authorship). The file is then transmitted (through the Internet) to the tax administration. The transmission constitutes a “request for authorization” to use a *digital invoice*.

STEP 2: The tax administration acts on the “authorization of use” request, without which there can be no binding contract. Authorization is not difficult – it (a) is fully automated (without human intervention), (b) is available 24/7, (c) requires only a basic check of the file for accuracy and completeness, and (d) should take a few seconds, and probably only a millisecond.

⁴⁶ Chile stated its electronic documents project in 2003 with a group of companies selected by the Internal Tax Service (SII). The Chilean system began with invoices, credit and debit notes, and dispatch forms, as well as purchase invoices. In 2005 the model was extended to export documents. In 2008 the *boleta*, or receipt issued to final consumers was allowed to be digital. The Chilean government (since 2005) has made available to small and medium sized firms a free application for the issuance of electronic documents. The companies must only have a certificate from the SII, a digital signature, internet access, and SII authorization as an electronic issuer. Chile has over 15,600 companies using *facturas electrónicas*, with 76% of this total representing micro and small companies. In 2009 the monthly total of tax documents reached 406,315. Newton Oller de Mello, Eduardo Mário Dias, Caio Fernando Fontana, & Marcelo Luiz Alves Fernandez, *The Evolution of the Electronic Tax Documents in Latin America*, Proceedings of the 8th WSEAS International Conference on SYSTEM SCIENCE and SIMULATION in ENGINEERING (2009) 294, available at: <http://dl.acm.org/citation.cfm?id=1938841>.

⁴⁷ In Brazil the *digital invoice* has been used for securing internal data for cross-border supplies among the twenty-seven Brazilian states since 2006. It is part of the Brazilian tax modernization program called the *Sistema Publico de Escrituracao Digital* or Public System for Digital Accounting (SPED). When it began the NF-e pilot project. Progress was rapid. By April 2009 there were 25,000 NF-e issuers. The CT-e pilot project began October 25, 2007. It involved two states (São Paulo and Rio Grande do Sul) and 43 companies and transportation firms. By March 1, and April 1, 2009 respectively the firms in Rio Grande do Sul and São Paulo began issuing legally binding CT-e documents. Large-scale adoption of the CT-e began in 2010, and by the end of 2010 there were over 500,000 firms issuing digitally signed, cross-border NF-e invoices. The system is fully in place today. Newton Oller de Mello, Eduardo Mario Dias, Caio Fernando Fontana & Marcelo Alves Fernandez, *The Implementation of the Electronic Tax Documents in Brazil as a Tool to Fight Tax Evasion*, PROCEEDINGS OF THE 13TH WORLD SCIENTIFIC AND ENGINEERING ACADEMY AND SOCIETY (WSEAS) INTERNATIONAL CONFERENCE ON SYSTEMS (2009) 449, 453, available at: <http://dl.acm.org/citation.cfm?id=1627575&picked=prox>

STEP 3: If the file is complete and accurate, the tax administration saves a copy and an electronic signature is produced. The electronic signature serves as an access key, and is used for verification of complete invoice data by the buyer, seller, the tax administration, or an approved third party. It will allow inspectors to immediately call up (in real-time) any invoice.

STEP 4: The seller then composes and transmits a proposed invoice to the buyer. It includes all of the data from the file along with the access key produced by the tax administration.

STEP 5: The buyer uses the access key to check the validity of the invoice. The buyer will then replicate the steps taken by the seller (above). The tax administration will re-verify, save this new file, and produce a second access key that will be returned to the buyer. The files from seller and buyer should match.

STEP 6: The buyer retains a copy of this file, and transmits it to the seller. A true invoice is now issued containing all of the contract data and both access keys. Goods will now be shipped, or services performed.

Figure 4: Diagram of basic digital invoice

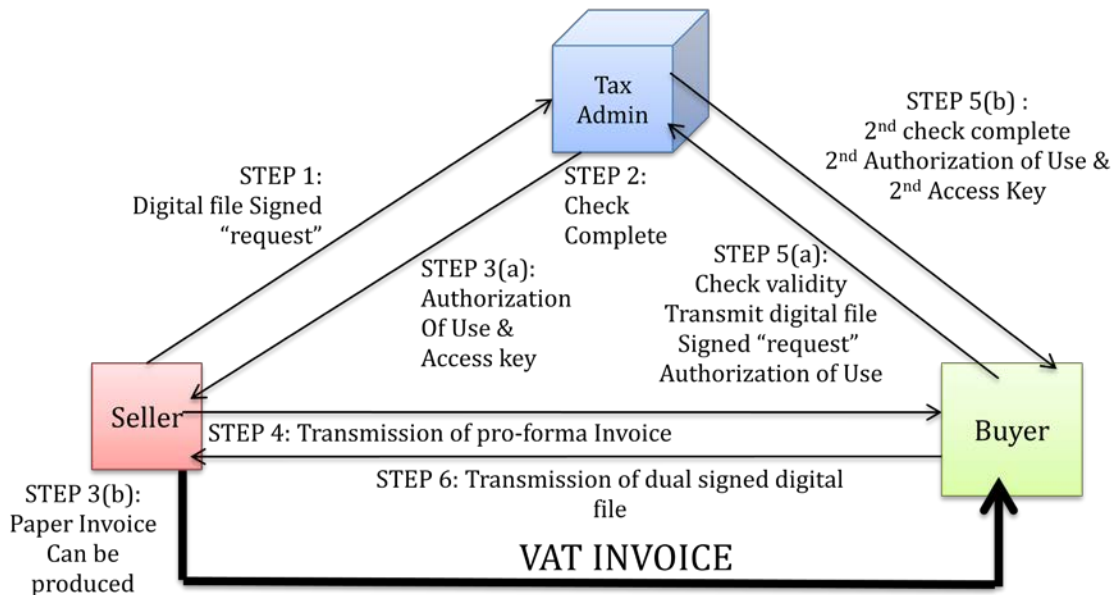

DICE with Customs Implementation

When DICE is applied in conjunction with a pure customs-based enforcement regime to monitoring intra-Gulf transactions fraud opportunities are significantly reduced. However, the scale and scope of a complete customs inspection at the borders will increase when agents are required to investigate VAT compliance in addition to their other commitments. DICE will reduce the impact of this added activity and minimize the

additional wait-time that will fall upon commercial trucking, but the traffic jam that currently exists at the borders will be going up, not down.

In terms of the common example, DICE requires that both the Saudi Diamond Dealer and B's Diamond Jewelry Business announce to their respective tax administrations an intention to enter into a diamond transaction. There are two permutations of how this transaction can occur: (1) with "B" walking into the Saudi Diamond Dealer's sales office in Riyadh, or (2) with "B" engaging in a remote (telephone, Internet, letter) contract with the Diamond Dealer. DICE does not distinguish between these transaction types – everything is treated the same way.

Submitting the required documentation is a very simple process. It can be handled with a free app on a cell phone.⁴⁸ Digital copies of the agreement are transmitted to the respective tax administrations (the Diamond Dealer notifying the Saudi Tax Administration, and "B's" Diamond Jewelry Business notifying the UAE Tax Administration). The key to DICE is that there is a full exchange of transactional data *before* the transaction occurs.

What DICE will do. All data associated with this transaction is secure (encrypted), copied, responded to with an access key, and then transmitted to the cloud by the tax administrations involved. The process will take less than a second. Because each party (seller, buyer, and both governments) has a key to access any of these documents it is a simple matter for Saudi and UAE tax administrations, or their respective customs officers to pull down the entire commercial chain when the diamonds arrive at the border.

Each tax administration will be able to perform sophisticated risk analysis with artificial intelligence (AI) programming applied to specific transactions, supplemented with related data streams collected in the cloud. The analytics should be on a par with the system SmartCloud Inc. system developed for Caerá, Brazil.⁴⁹

The core attribute of DICE is that it facilitates real-time enforcement. DICE will allow either tax administration (Saudi or UAE) to block the VAT attributes of a transaction (by voiding an access key) *before* the diamonds arrive at the customs border crossing. Customs will have the same capacity to void the VAT attributes *once the diamonds arrive*.

⁴⁸ A version of this app developed by Data Tech International can be found at: <https://itunes.apple.com/us/app/inetcpo-tc/id1133886976?mt=8>.

⁴⁹ For a discussion of the project in Caerá, Brazil that SmartCloud Inc. is installing an artificial intelligence (AI) engine see: in Caerá see: Inter-American Development Bank Project BR-L1174 at: http://www.iadb.org/en/projects/project-description-title_1303.html?id=2044%2FOC-BR%3BBR-L1174 ; see also SmartCloud Inc.'s discussion of Fraud Prevention at: <http://www.smartcloudinc.com/#!/fraud-prevention-v2a/c9i1>

Figure 5: DICE – pure customs implementation

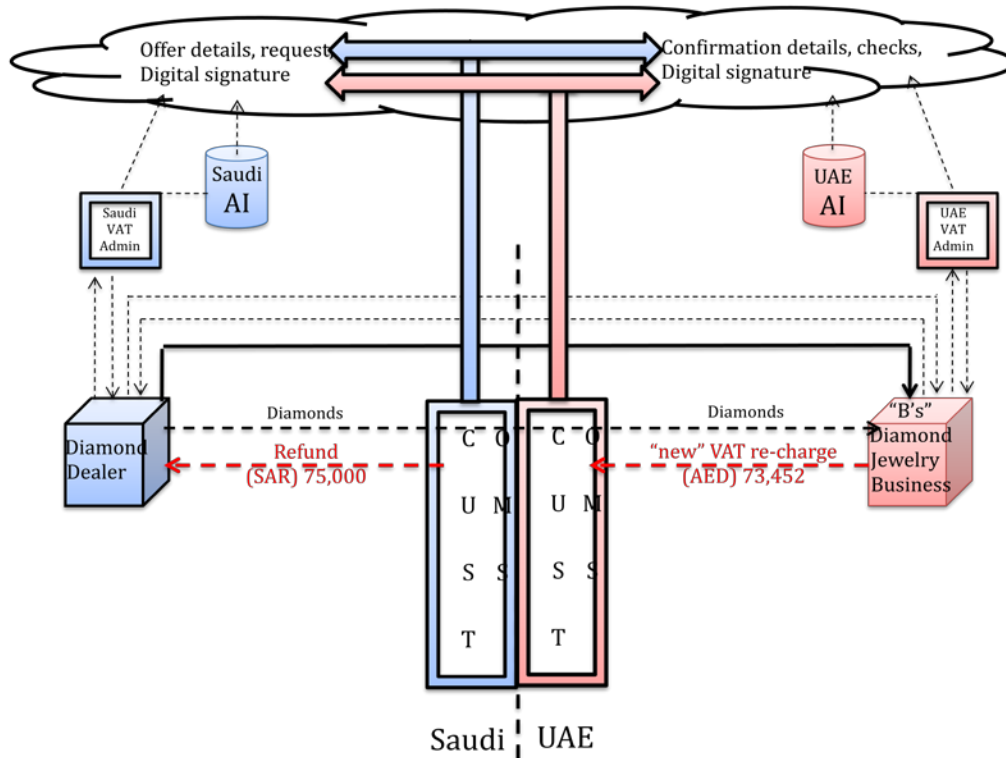

What DICE will not do. DICE will not be able to detect if “fake diamonds” are being presented to customs agents, although it will be able to connect/ or associate the “fake diamonds” presented at the border with the Diamond Dealer and “B’s” Diamond Jewelry Business. It would make it difficult for the Diamond Dealer to avoid reporting the sale, and for “B” to disappear without paying the VAT, and might discourage this practice. However, if any of this happened the risk-analyzing AI would remember it and raise questions about subsequent transactions that might look “suspicious.”

DICE would also make it difficult for a fraudster to show up at customs with *both* fake diamonds and fraudulent invoices seeking to trick customs into issuing a refund when no transaction has occurred.

DICE with a customs implementation will not be able to deal with any of the frauds in tradable services among the GCC Member States. Customs oversight is limited to goods transactions, which means a second system (in addition to this one) is needed to fully secure intra-Gulf transactions.

DICE will never produce a net reduction in the time at the border crossing. Placing VAT compliance at the border-crossings will increase wait-times. This is an inescapable fact. Commercial waiting times will increase. DICE will not reduce them.

DICE with Reverse Charge Implementation

When DICE is applied in conjunction with a *reverse charge* enforcement regime as a structure to monitor intra-Gulf transactions MTIC and MTEC fraud opportunities are significantly reduced. Unfortunately, the frauds are not eliminated.

The *reverse charge* mechanism places VAT-free supplies in the hands of individuals who can sell the supplies, collect VAT, and then disappear. With DICE in place this fraud becomes more difficult. DICE should alert the authorities early, and success becomes a race of fraudsters against enforcement. Fraudsters will search for supplies of high value, readily fungible, and mobile. Diamonds may be one of the commodities that could be used.

DICE operates no differently when it is joined with a *reverse charge* implementation than when it operates with a *customs* implementation. The common example applies in exactly the same manner as it did with customs. Each business along the commercial chain will be required to digitally report taxable transactions in real-time to their respective tax administrations. See figure 6 below.

Figure 6 is an adaptation of figure 2 (on the *reverse charge* implementation), supplemented with figure 4 (on the DICE application). For readability purposes some parts of Figures 2 and 4 were omitted when constructing figure 6. In particular:

- Figure 6 omits (from figure 2) the arrows showing return filing, and the reference to the 45 to 105 day time-gap which is inherent in any reverse charge solution – this is the fraudster’s head-start on the authorities;
- Figure 6 omits (from figure 4) the arrows detailing the submission of encrypted records to the tax authorities, and the return of keys by the VAT administrations to the taxpayers.

The discussion below assumes that the reader understands that these omissions were not modifications of the DICE or the *reverse charge*, but just necessary simplifications of the diagram presentation.

Figure 6: DICE – reverse charge implementation

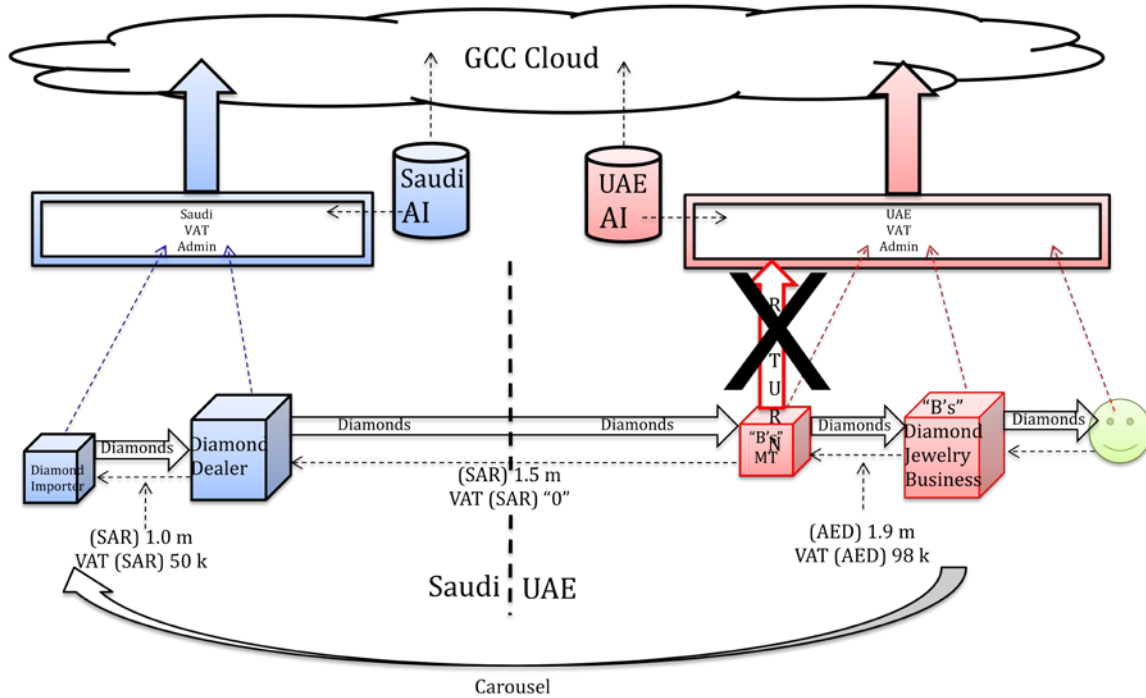

The standard MTIC fraud pattern set out in figure 2 shows “B” setting up an entity (in the UAE) called “B’s” MT to purchase diamonds from a Diamond Dealer (in Saudi Arabia). No VAT is paid on the cross-border sale, because of the *reverse charge*. “B’s” MT is obligated to self assess this VAT and remit it to the UAE.

Instead of complying with the law, “B’s” MT re-sells the diamonds with VAT (to B’s” Diamond Jewelry Business), collects VAT, and disappears. Barring an enforcement action, “B’s” Diamond Jewelry Business is allowed to deduct the VAT paid. The missing trader never reports, or pays over the VAT. In this pattern the tax administrations really have very little chance of identifying the fraud *before* the returns are due (45 or 105 days after the underlying transaction). DICE endeavors to accelerate the identification of potential frauds.

DICE requires each participant in the commercial chain to digitally record their transactions in real-time, and transmit this data to the tax authorities. Each tax authority immediately uploads this data to the common GCC Cloud where AI programming will search for fraud patterns.

For example, the Saudi AI system will have access to both the direct Saudi files, and the combined GCC files in the cloud. Saudi AI should notice that the Saudi Diamond Dealer was selling significant volumes of diamonds to “B’s” MT. If through the shared data-base the Saudi AI considered this transaction to be highly risky the Saudi tax administration could take steps to void “authorization of use” and the “access key” to the transaction.

This action would prevent the Saudi Diamond Dealer from “zero-rating” its transaction with “B’s” MT. It would make the Diamond Dealer liable for the VAT.

If it had not already identified the fraud attempt, the UAE AI program will pick up on the Saudi “warning” and direct attention immediately to “B’s” MT. The UAE tax authority would have access to the entire filing, and registration history of “B’s” MT. It would be particularly telling if “B’s” MT had audit problems in the past, or if “B’s” MT was found to be no more than a letter-box entity.

The problem with any *reverse charge* is that risk analysis conducted by AI will be much better in identifying a second or a third fraud attempts than it will be in finding the first fraud attempt. However, AI is not just a historical data-base search engine. It thinks, and it learns. It makes inferences about one set of transactions based on patterns of activity elsewhere in the system. There are standard (and economic segment specific) indications of fraud, and an AI system could raise a warning if (for example) large unexplained sales of diamonds were trading rapidly across borders among new, un-established traders.

Nevertheless, finding all the fraud will be difficult in a DICE *reverse charge* implementation. If (for example and as set out in the common example), “B” *walks into the Diamond Dealer’s shop in Riyadh*, and if he presents a UAE VAT ID, then it is entirely possible that “B” could pay cash and walk out with 25 princess diamonds free of VAT in 10 minutes.⁵⁰ Like any good fraudster “B” could have more than one registered company “on the shelf.” By simply move the diamonds from one pocket to the other, and while representing that he is a diamond-seller from another Saudi company, he could re-sell the diamonds he bought 10 minutes ago to another Saudi diamond merchant in the store one door down.

Because this re-sale would be a Saudi-to-Saudi transaction VAT would be imposed. It is conceivable that this one-man carousel could go on all morning with four complete circles an hour. Just using the figures in the basic diagram, with an initial investment of (SAR) 2,000,000 (\$533,304.90), “B” would double his investment by 1:00 pm that afternoon.⁵¹ Cash transactions would be preferable (as would an airplane ticket out of the country for later that afternoon). See figure 7 below:

⁵⁰ Under *reverse charge* treatment, when “B” convinces the diamond merchant that the sale is B2B, and that he is a UAE business, the merchant will draft an invoice with a Saudi VAT of 0%. Although the most common way of doing this would be to present the diamond merchant with a valid VAT ID from the UAE, in the EU the ECJ has deemed the VAT ID to be helpful, but not a necessary requirement. *Vogtländische Straßen-, Tief- und Rohrleitungsbau GmbH Rodewisch (VSTR) v. Finanzamt Plauen*, Case C-587/10 (September 27, 2012). As a result, the invoice will demand payment of (SAR) 1.5 million for 25, 1-carat princess diamonds and include no Saudi VAT.

Under EU rules the merchant would need to believe (with objective evidence) that the diamonds were going to physically leave the jurisdiction. *Teleos, plc & Others v. Commissioners of Customs & Excise*, Case C-409/04 (September 27, 2007).

⁵¹ Assuming “B” starts at 8:00 am and completes 4 circles each hour. 20 complete circles times (SAR) 100,000 per circle yields (SAR) 2,000,000 in unreported Saudi VAT (\$533,304.90).

Figure 7: DICE – reverse charge implementation – Missing Trader

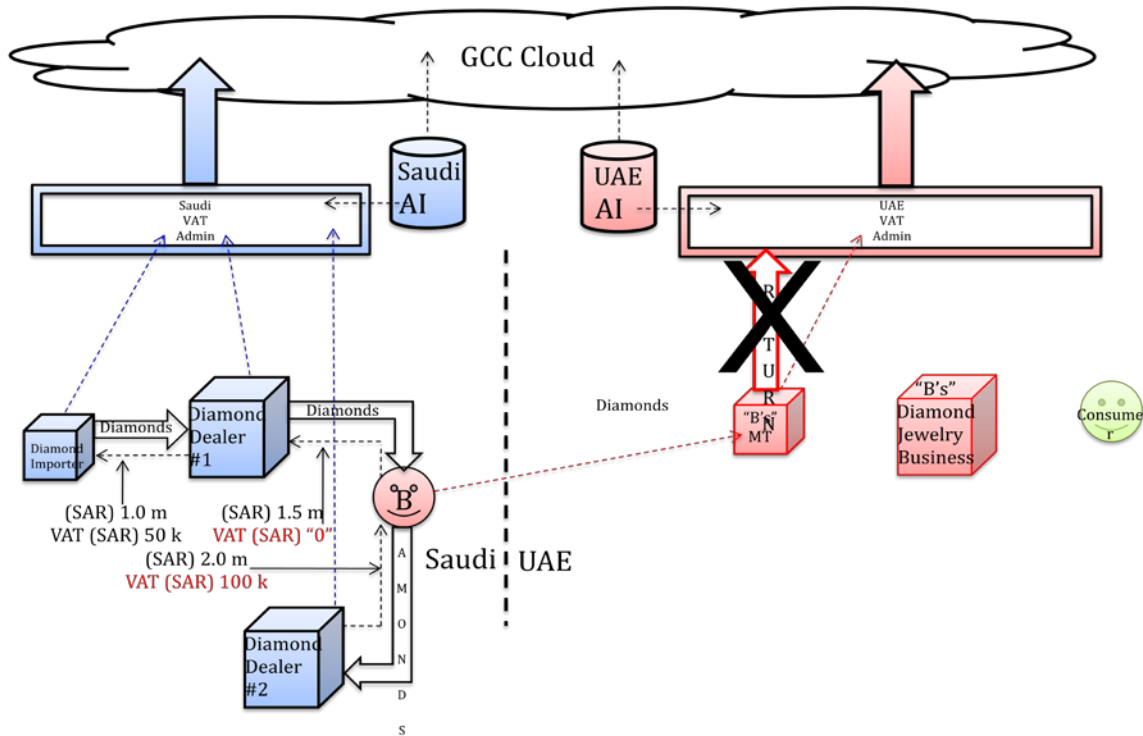

DICE would provide the data needed to identify this fraud when it noticed the purchase and re-purchase of diamonds by “B” and the immediate re-sale of those diamonds on the same street for a continual (SAR) 500,000 profit. The AI program would identify a considerable anomaly in the marketplace if diamond dealers engaged in businesses next to each other bought and sold the same product for considerable price differentials time after time.

But what if the profit margin was reduced? What if the “shelf” entity “B” used for each transaction was different each time? Both the Saudi AI and the UAE AI programs would probably suspect this series of transactions, but the problem might well be that “B” has cash in hand and an airplane ticket at the ready. It is the *reverse charge* implementation that has allowed “B” to hold the VAT he received from Diamond Dealer #2. It is the *reverse charge* implementation that allows “B” delay payment of the VAT until a return is filed in another 45 to 105 days.

DICE with One-Stop-Shop Implementation

When DICE is applied in conjunction with a *one-stop-shop* enforcement regime to monitor intra-Gulf transactions MTIC and MTEC fraud opportunities are eliminated. The reason is easy to see. A *one-stop-shop* corrects the flaw of the *reverse charge* mechanism.

The flaw in the *reverse charge* mechanism is that it places VAT-free supplies in the hands of individuals who can sell the supplies on, collect VAT, and then disappear. That never happens with a *one-stop-shop*. If there are difficulties with the *one-stop-shop* they are in the politics of the community not in the data or the ability to monitor compliance with the VAT. The core issue is that there is a *perception of loss of sovereignty* when one jurisdiction depends on another for the collection and remission of significant amounts of revenue. Resolving this perception issue needs to be dealt with in the GCC Framework agreement.

Sovereignty concerns are exacerbated when there are pressures for rate increases. The *one-stop-shop* mechanism has significant difficulties with non-aligned rates and variable tax bases. These difficulties are predictable. If the VAT becomes a sizable revenue stream for GCC counties, and if some (but not all) countries want to raise rates from 5% closer to the EU rates of 15%, then there will be under-collection in some cases and over-collection in others. If the GCC adopts a *one-stop-shop*, then it needs to be ready with a back-up plan in case disagreements arise. That plan should probably include DICE with a mix of *customs* and *reverse charge* methodologies.

DICE operates no differently when it is joined with a *one-stop-shop* implementation than it operates with a *customs* or *reverse charge* implementation. The common example applies in exactly the same manner. Each business along the commercial chain will be required to digitally report taxable transactions in real-time to their respective tax administrations. See figure 8 below (a DICE-based modification of figure 3 above).

In this figure a Saudi Diamond Importer sells to the Saudi Diamond Dealer who re-sells 25, 1-carat princess diamonds to “B’s” Diamond Jewelry Business. The Saudi Diamond Dealer collects the UAE VAT from “B’s” Diamond Jewelry Business and includes the VAT collected with its Saudi return.

The entire invoice chain of the diamond trades, up to and including the final sale to consumers, is encrypted, and uploaded to the tax administrations that certify the transaction, and send the encrypted data to the GCC Cloud where it can be accessed by anyone with an “access key.”

Saudi and UAE AI programs will analyze the data streams under identified risk parameters. Enforcement tools will include the ability to void a deduction by removing digital approvals. After the Saudi Diamond Dealer’s return is filed with the Saudi tax authorities, a payment will issue to the UAE for all the accumulated VAT on the 25 princess diamonds.

Figure 8: DICE – one-stop-shop implementation

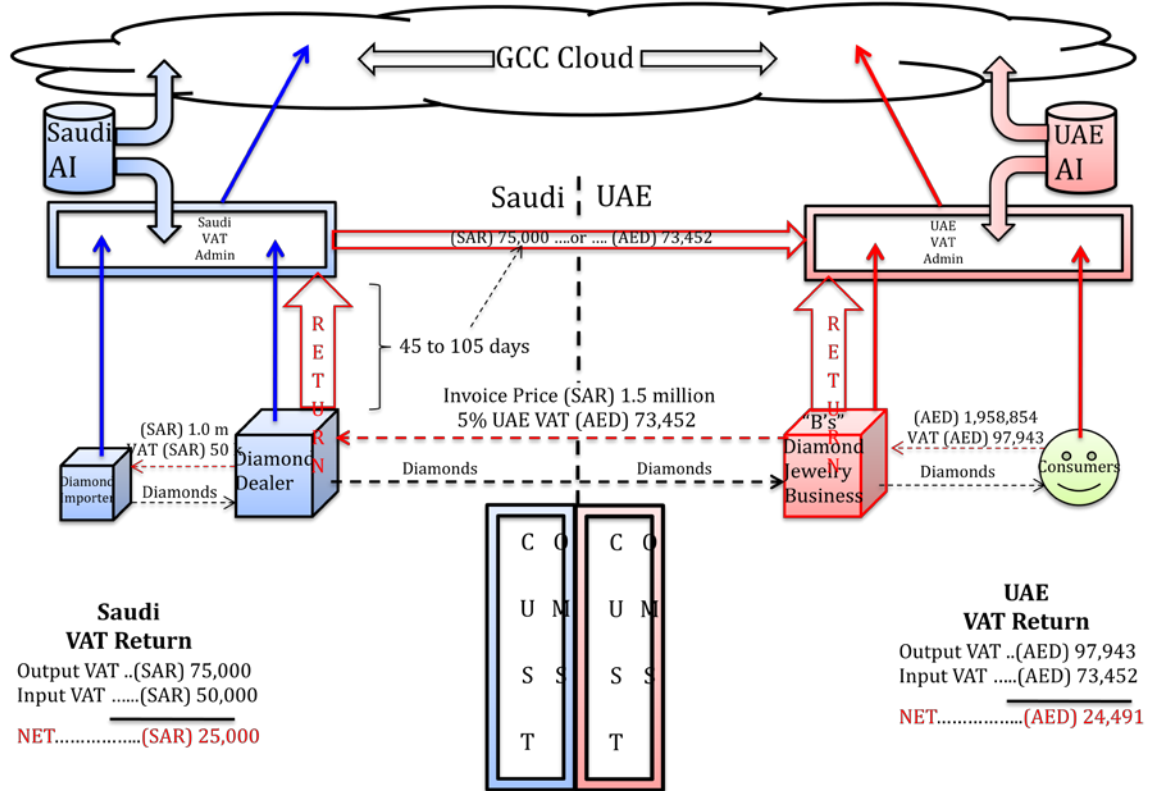

The earlier discussion of the *one-stop-shop* specified three problematical areas that needed to be addressed if the GCC were to adopt a one-stop-shop: (1) the absence of a *real-time data exchange*, (2) *tax rate and tax base differentials* among the Member States, and (3) the loss of “*audit*” sovereignty.

The second issue has been resolved by the GCC Framework agreement.⁵² The remaining two concerns are resolved when the *one-stop-shop* is coupled with DICE.

The *real-time data exchange* is the essence of DICE. Each transaction, and each commercial player in a supply chain will transmit records (invoices or receipts) of each transaction in secure, encrypted files to the tax administration of their respective countries. These records will be forwarded to the GCC Cloud and shared among the countries, businesses, and individuals that have reason to access the data.

The reason that data exchanges are needed in real-time is that the UAE needs to be able to both (a) identify fraudsters early-on in their activities, and (b) estimate economic VAT flows. For example, the UAE would like to know sooner than 105 days down the road that it should be expecting (AED) 73,452 from the Saudi Treasury. It will get (AED) 24,491 from domestic consumer sales, but it is entitled to more. The (AED)

⁵² *Supra* note **Error! Bookmark not defined.**

24,491 will be deposited with the VAT return. The amount of (AED) 73,452 is additional consumption, representing value that was added outside of the UAE. However, all consumption is within the UAE.

“*Audit*” *sovereignty* is a related concern. Under both the *customs* and the *reverse charge* approaches to monitoring intra-Gulf trade, *UAE taxes* were collected either by *UAE customs agents* at the border, or from *UAE businesses*. Under these approaches the UAE does not depend on a Saudi return, or wait on a Saudi tax agent’s audit, nor will the UAE be waiting for funds to be transmitted by the Saudi Treasury. This is not to say that the UAE does not trust the Saudi authorities, it is just to say that the UAE, like any government, likes to control its own revenue streams.

Under the *one-stop-shop* audit, *sovereignty* is held hostage (in the common example instance) by the Saudi Diamond Dealer. The Saudi Diamond Dealer collects the UAE VAT without registering as a UAE taxpayer or filing a UAE return. However, if all GCC transactional data is encrypted and sent to the GCC Cloud, the UAE can audit independently or in conjunction with the Saudi tax administration utilizing this common data-base. All *sovereignty* issues should be resolved.

CONCLUSION

This paper has isolated one aspect of the Arabian VATs – how they will deal with intra-Gulf transactions in goods. The three established regimes: *customs enforcement*, a *reverse charge*, and a *one-stop-shop* are considered independently and then in conjunction with a technological implementation (DICE). In each instance technology will bring significant improvements to these traditional systems.

There is a distinct preference for a *one-stop-shop* working in conjunction with DICE, although the GCC needs a back-up plan in case the political pressures on uniform rates pull the GCC out of rate-harmony. There is no discussion in this paper of the special problems that will confront the GCC when tradable services are considered. A separate (follow-up) paper will examine this issue.

Much of what is set out here already has a proven track record of success, although most of the advanced technology is not proven in the EU. The EU still has a long way to go to approach even the universal digital invoices that have been used for over a decade in the Brazilian *Sistema Publico de Escrituracao Digital* or Public System for Digital Accounting (SPED). Storing common transactional data in a GCC Cloud where AI performs advanced fraud spotting risk analysis can be seen in Caerá, Brazil.⁵³ Moving data to the GCC Cloud can be as easy as utilizing a free app downloaded from the iStore, and installed on a cell phone as in Rwanda, and soon to be rolled out in Ontario, Canada.⁵⁴

⁵³ *Supra* note 49.

⁵⁴ *Supra* note 48.

For VAT specialists, these are exciting developments. The GCC appears to be embarking on a highly modern, technologically advanced VAT system that will apply the best learning from around the globe. Over the next year and a half we expect to see more technology mandated in the GCC. Just last month Saudi Arabia mandated that all businesses in the Kingdom keep their commercial books, financial statements, and invoices electronically and in the Arabic language. Officials at the Ministry of Trade and Investment made it very clear that the reason for the mandate was to pave the way for the VAT.⁵⁵

⁵⁵ Naif Al Rajhi, *An Obligation that the Private Sector will Apply Electronic Billing in preparation for VAT and Selective Taxes*, ALEQT.COM available at: http://www.aleqt.com/2016/08/14/article_1077786.html